

Operating and Maintaining the P10 Console



Operating and Maintaining the P10 Console

PRECOR®

Edition Information

OPERATING AND MAINTAINING THE P10 CONSOLE

P/N 302291-101 rev A

Copyright © January 2013 Precor Incorporated. All rights reserved. Specifications subject to change without notice.

Trademark Note

Precor, AMT, EFX, and Preva are registered trademarks of Precor Incorporated. Other names in this document may be the trademarks or registered trademarks of their respective owners.

Intellectual Property Notice

All rights, title, and interests in and to the software of the Preva Business Suite, the accompanying printed materials, any copies of such software, and all data collected via the Preva Business Suite, are exclusively owned by Precor or its suppliers, as the case may be.

Precor is widely recognized for its innovative, award-winning designs of exercise equipment. Precor aggressively seeks U.S. and foreign patents for both the mechanical construction and the visual aspects of its product design. Any party contemplating the use of Precor product designs is hereby forewarned that Precor considers the unauthorized appropriation of its proprietary rights to be a very serious matter. Precor will vigorously pursue all unauthorized appropriation of its proprietary rights.

Precor Incorporated
20031 142nd Ave NE, P.O. Box 7202
Woodinville, WA 98072-4002
1-800-347-4404

<http://www.precor.com>

Important Safety Instructions

Important: Save these instructions for future reference.

Read all instructions in the documentation provided with your exercise equipment, including all assembly guides, user guides, and owner's manuals, before installation of this device.

Note: This product is intended for commercial use.

The display apparatus (hereinafter referred to as the *console*) is intended to be shipped with new Precor exercise equipment (hereinafter referred to as the *base unit*). It is not packaged for individual sale.

WARNING To prevent injury, the console must be attached securely to the base unit following all assembly and installation instructions shipped with the base unit. The console is intended to be connected to AC mains power through the furnished power supply ONLY. It should be powered on only when installed as described in the assembly and installation instructions shipped with the base unit. The console is intended for use only with Precor fitness equipment, not as a standalone device.

Safety Precautions

Always follow basic safety precautions when using this equipment to reduce the chance of injury, fire, or damage. Other sections in this manual provide more details of safety features. Be sure to read these sections and observe all safety notices. These precautions include the following:

- Read all instructions in this guide before installing and using the equipment and follow any labels on the equipment.

- Make sure all users see a physician for a complete physical examination before they begin any fitness program, particularly if they have high blood pressure, high cholesterol or heart disease; have a family history of any of the preceding conditions; are over the age of 45; smoke; are obese; have not exercised regularly in the past year; or are taking any medication.

French equivalent of the above notice, for Canadian markets: *Il est conseillé aux utilisateurs de subir un examen médical complet avant d'entreprendre tout programme d'exercice, en particulier s'ils souffrent d'hypertension artérielle, ou de cardiopathie ou ont un taux de cholestérol élevé, s'ils ont des antécédents familiaux des précédentes maladies, s'ils ont plus de 45 ans, s'ils fument, s'ils sont obèses, s'ils n'ont pas fait d'exercices réguliers au cours de l'année précédente ou s'ils prennent des médicaments. Si vous avez des étourdissements ou des faiblesses, arrêtez les exercices immédiatement.*

- Do not allow children, or people unfamiliar with the operation of this equipment, on or near it. Do not leave children unsupervised around the equipment.
- Make sure all users wear proper exercise clothing and shoes for their workouts and avoid loose or dangling clothing. Users should not wear shoes with heels or leather soles, and they should check the soles of their shoes to remove any dirt and embedded stones. They should also tie long hair back.
- Never leave the equipment unattended when it is plugged in. Unplug the equipment from its power source when it is not in use, before cleaning it, and before providing authorized service.

Note: The optional power adapter is considered a power source for self-powered equipment.

- Use the power adapter provided with the equipment. Plug the power adapter into an appropriate, grounded power outlet as marked on the equipment.
- Care should be taken when mounting or dismantling the equipment.
- For Treadmills: Do not use typing or web surfing features while walking at speeds that exceed a **slow and relaxed leisurely pace**. Always stabilize yourself by holding a stationary handle bar while using typing or web surfing features.
- For AMT and EFX: Always stabilize yourself by holding a stationary handle bar while using typing or web surfing features.

- Read, understand, and test the emergency stop procedures before use.
- Keep the power cord or optional power adapter and plug away from heated surfaces.
- Route power cables so that they are not walked on, pinched, or damaged by items placed upon or against them, including the equipment itself.
- Ensure the equipment has adequate ventilation. Do not place anything on top of or over the equipment. Do not use on a cushioned surface that could block the ventilation opening.
- Assemble and operate the equipment on a solid, level surface.
- **SPACING**—The below minimum spacing recommendations are based on a combination of the ASTM (U.S.) voluntary standards and EN (European) regulations as of October 1, 2012, for access, passage around, and emergency dismount:
 - **Treadmills**—a minimum of 0.5 m (19.7 in.) on each side of the treadmill and 2 m (78 in.) behind the machine.
 - **Cardio equipment other than treadmills**—a minimum of 0.5 m (19.7 in.) on at least one side, and 0.5 m (19.7 in.) behind or in front the machine.

Careful consideration should be given to the requirements of the Americans with Disabilities Act (ADA), US Code 28 CFR (see Section 305). ASTM standards are voluntary and may not reflect current industry standards. The actual area for access, passage around, and emergency dismount is the responsibility of the facility. The facility should consider the total space requirements for training on each unit, voluntary and industry standards, and any local, state, and federal regulations. Standards and regulations are subject to change at any time.

Important: *These spacing recommendations should be used when positioning equipment away from sources of heat, such as radiators, heat registers, and stoves. Avoid temperature extremes.*

- Keep equipment away from water and moisture. Avoid dropping anything on or spilling anything inside the equipment to prevent electric shock or damage to the electronics.

- When using the treadmill, always attach the safety clip to your clothing before beginning your workout. Failure to use the safety clip may pose a greater risk of injury in the event of a fall.
- Keep in mind that heart rate monitors are not medical devices. Various factors, including the user's movement, may affect the accuracy of the heart rate readings. The heart rate monitors are intended only as exercise aids in determining heart rate trends in general.
- Do not operate electrically powered equipment in damp or wet locations.
- Never operate this equipment if it has a damaged cord or plug, if it is not working properly, or if it has been dropped, damaged, or exposed to water. Call for service immediately if any of these conditions exist.
- Maintain the equipment to keep it in good working condition, as described in the *Maintenance* section of the owner's manual. Inspect the equipment for incorrect, worn, or loose components, and then correct, replace or tighten prior to use.
- If you plan to move the equipment, obtain help and use proper lifting techniques.
- Equipment Weight Restrictions: Do not use the treadmill if you weigh more than 500 pounds (225 kg). If you weigh more than 350 pounds (160 kg), do not run on the treadmill. For all other fitness equipment, the weight limit is 350 pounds (160 kg).
- Use the equipment only for its intended purpose as described in this manual. Do not use accessory attachments that are not recommended by Precor. Such attachments may cause injuries.
- Do not operate the equipment where aerosol (spray) products are being used or where oxygen is being administered.
- Do not use outdoors.
- Do not attempt to service the equipment yourself, except to follow the maintenance instructions in the owner's manual.
- Never drop or insert objects into any opening. Keep hands away from moving parts.

- Do not set anything on the stationary handrails, handlebars, control console, or covers. Place liquids, magazines, and books in the appropriate receptacles.
- Do not lean on or pull on the console at any time.

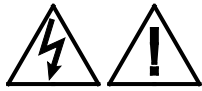

CAUTION: DO NOT remove the cover, or you may risk injury due to electric shock. Read the assembly and maintenance guide before operating. There are no user-serviceable parts inside. Contact Customer Support if the equipment needs servicing. For use with single phase AC power only.

Hazardous Materials and Proper Disposal

The batteries within self-powered equipment contain materials that are considered hazardous to the environment. Federal law requires proper disposal of these batteries.

If you plan to dispose of your equipment, contact Precor Commercial Products Customer Support for information regarding battery removal. Refer to *Obtaining Service*.

Product Recycling and Disposal

This equipment must be recycled or discarded according to applicable local and national regulations.

Product labels, in accordance with European Directive 2002/96/EC concerning waste electrical and electronic equipment (WEEE), determine the framework for the return and recycling of used equipment as applicable throughout the European Union. The WEEE label indicates that the product is not to be thrown away, but rather reclaimed upon end of life per this Directive.

In accordance with the European WEEE Directive, electrical and electronic equipment (EEE) is to be collected separately and to be reused, recycled, or recovered at end of life. Users of EEE with the WEEE label per Annex IV of the WEEE Directive must not dispose of end of life EEE as unsorted municipal waste, but use the collection framework available to customers for the return, recycling, and recovery of WEEE. Customer participation is important to minimize any potential effects of EEE on the environment and human health due to the potential presence of hazardous substances in EEE. For proper collection and treatment, refer to *Obtaining Service*.

Regulatory Notices for Cardiovascular Exercise Equipment

The regulatory information in this section applies to the exercise equipment and its control console.

Safety Approvals for Cardiovascular Equipment

Precor equipment has been tested and found to comply with the following applicable safety standards.

Cardiovascular Type Equipment:

- CAN/CSA, IEC, EN 60335-1 (Household and similar electrical appliances - Safety)
- EN 957 (Stationary training equipment, class S/B compliant equipment)

Radio Frequency Interference (RFI)

This Precor exercise equipment conforms to the following national standards defining acceptable limits for radio frequency interference (RFI).

Federal Communications Commission, Part 15

This equipment has been tested and found to comply with the limits for a Class A digital device, pursuant to Part 15 of the FCC Rules. These limits are designed to provide reasonable protection against harmful interference in a commercial installation. The equipment generates, uses, and can radiate radio frequency energy and, if not installed and used in accordance with the owner's manual instructions, can cause harmful interference to radio communications.

Operation is subject to the following two conditions: (1) this device may not cause harmful interference, and (2) this device must accept any interference received, including interference that may cause undesired operation.

WARNING Per FCC rules, changes or modifications not expressly approved by the manufacturer could void the user's authority to operate the equipment.

Industry Canada

This device complies with RSS-210:2007 of the Spectrum Management & Telecommunications Radio Standards Specification. Operation is subject to the following two conditions: (1) this device may not cause harmful interference, and (2) this device must accept any interference received, including interference that may cause undesired operation.

This Class A digital apparatus complies with Canadian ICES-003.

Cet appareil numérique de la classe A est conforme à la norme NMB-003 du Canada.

ATTENTION: Haute Tension
Débranchez avant de réparer

European Applications

CE compliance is claimed to the following directives:

- 2004/108/EC EMC Directive
- 2006/95/EC LVD Directive
- 2002/95/EC RoHS Directive

Directive compliance has been verified to the following standards:

- EN 55022
- EN 55024
- EN 60335-1
- EN 60065 (P80 and PVS)

Electrical Recommendations: 120 V and 240 V Treadmills

Note: This is a recommendation only. NEC (National Electric Code) guidelines or local region electric codes must be followed.

You should have received a power cable that meets your local electrical code requirements along with the equipment. Precor treadmills must be connected to a 20 amp individual branch circuit that can be shared only with one PVS. If you need additional help with the power connections contact your Precor authorized dealer.

Important: An individual branch circuit provides a hot conductor and neutral conductor to a receptacle. The conductors must not be looped, "daisy-chained", or connected to any other conductors. The circuit must be grounded according to NEC guidelines or local region electric codes.

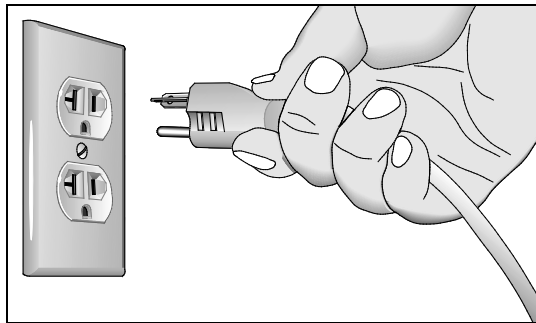

Figure 1: North American 120-volt, 20-amp power receptacle

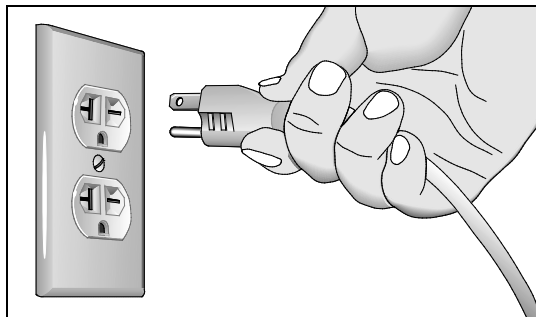

Figure 2: North American 240-volt, 20-amp power receptacle

Electrical Recommendations: All Equipment Excluding Treadmills

Note: This is a recommendation only. NEC (National Electric Code) guidelines or local region electric codes must be followed.

For equipment fitted with a P80 console or Personal Viewing System (PVS) screen a separate power connection is required. For a 20 amp branch circuit up to 10 screens can be connected. If the branch circuit has any other devices plugged into the circuit, then the number of screens must be reduced by the wattage of the other devices.

Note: The typical splitter power cords that have IEC-320 C13 and C14 plugs have a recommended maximum capacity of five screens.

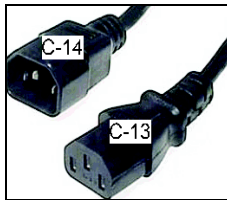

Figure 3: IEC-320 C13 and C14 plugs

Obtaining Service

Do not attempt to service the equipment except for maintenance tasks. If any items are missing, contact your dealer. For more information regarding customer support numbers or a list of Precor authorized service centers, visit the Precor web site at <http://www.precor.com>.

Table of Contents

| | |
|--|-----------|
| Important Safety Instructions | 3 |
| Safety Precautions..... | 3 |
| Hazardous Materials and Proper Disposal..... | 7 |
| Product Recycling and Disposal | 7 |
| Regulatory Notices for Cardiovascular Exercise Equipment | 8 |
| Electrical Recommendations: 120 V and 240 V Treadmills..... | 10 |
| Electrical Recommendations: All Equipment Excluding Treadmills..... | 11 |
| Obtaining Service..... | 11 |
| Getting Started | 15 |
| Activating the Console for Self-Powered Equipment | 15 |
| Identifying Parts of the Console..... | 17 |
| Setting Up the Console | 19 |
| System Settings..... | 19 |
| Club Parameters..... | 20 |
| Viewing the Informational Displays | 24 |
| User ID Entry with CSAFE Equipment..... | 28 |
| Introducing Users to the P10 Console | 29 |
| Using the Touch Heart Rate Feature | 29 |
| Using a Chest Strap Transmitter..... | 31 |
| Using the Treadmill Safety Clip | 32 |
| Treadmill Auto Stop™ (Automatic Stop) Function..... | 34 |
| Starting a Workout | 35 |
| Starting a Preset Programmed Workout..... | 36 |
| Pausing and Resuming an Exercise Session | 36 |
| Ending a Session..... | 38 |
| Maintenance | 39 |
| Cleaning the Console and Display | 39 |
| Changing the Belt (Newer Model AMT Only)..... | 40 |

Getting Started

The P10 console offers administrators the ability to set default values that meet their specific needs. These values include items like language, units of measure, and setting a maximum allowed workout time for each piece of equipment.

Activating the Console for Self-Powered Equipment

Precor equipment is either self-powered or externally powered using an optional power adapter. Self-powered equipment requires the user exercise to initialize the console. This section provides more detail about powering equipment.

Activating the Console for Self-Powered Equipment

On self-powered equipment, when a user starts exercising, the console initializes and displays the Welcome banner. A minimum rate of motion must be maintained for the Welcome banner to appear. The words PEDAL FASTER (or the equivalent message depending on the equipment type) appear in the display when the rate of motion drops below the minimum requirements.

The equipment saves its battery charge by moving into a shutdown mode. If the user does not maintain the minimum rate of motion, a 30-second shutdown process begins.

In this mode, the console displays a countdown indicator and ignores all keypresses. If no movement is detected or the rate of motion remains below the minimum, the indicator changes as the countdown continues.

Note: The user can resume exercising before the countdown period elapses and the workout will continue from the point at which it was paused.

Optional Use of the Power Adapter

An optional AC power adapter provides sustained power to the equipment. This adapter allows you to change settings without having to pedal the equipment. To purchase the power adapter, contact your dealer.

If you purchase the optional power adapter, you must also purchase the internal cable kit. The kit supplies the cable, bracket, and fasteners that connect the power adapter to the lower electronics board.

CAUTION: The internal cable kit must be installed by authorized service personnel. Do not attempt installation on your own as you could void the Precor Limited Warranty. For more information, refer to *Obtaining Service*.

Important: *If this equipment includes a P80 console, the optional power adapter and the internal cable kit must still be installed to provide continuous power to the base unit and support its internal battery.*

Once the internal cable kit is installed, you can plug the optional power adapter into the equipment. Plug the opposite end into the appropriate power source for your equipment (120 V or 240 V). Review the safety instructions found at the beginning of this manual before using the power adapter.

CAUTION: When the optional power adapter is in use, make sure that the power supply cord does not create a safety hazard. Keep it out of the way of traffic and moving parts. If the power supply cord or power conversion module is damaged, it must be replaced.

The control console functions differently when the power adapter is connected. Because the power adapter provides a constant source of power, a user can pause for brief periods without initiating shutdown procedures. When the pause time limit expires and the user has not resumed exercising, the console returns to the Welcome screen. The default pause time is 30 seconds for all fitness equipment. Refer to the manual for your control console for instructions on setting or changing the pause time limit.

Identifying Parts of the Console

The following figure provides information about the console keys. The number and actions of the console keys may differ slightly depending on the type of equipment.

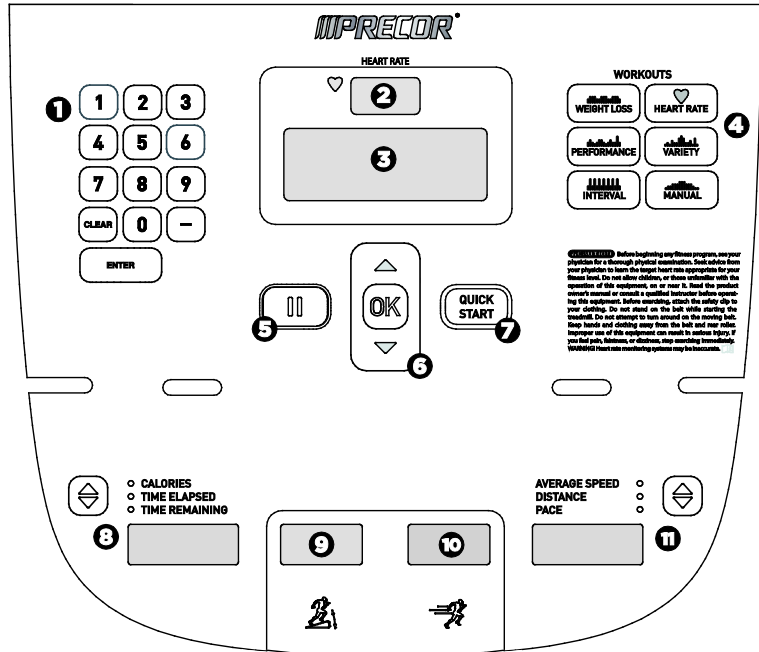

Figure 4: P10 console keys

Table 1. Parts of the console

| Number | Name | Details |
|----------|---------------|---|
| 1 | Number pad | Enter numerical information such as age, weight, and passwords. You can also enter and change channels using the number pad. <ul style="list-style-type: none"> Press Clear to delete the numbers you entered. Press Enter to confirm your selection. |
| 2 | Heart Rate | Displays your current heart rate. |
| 3 | Lower Display | Displays graphical information about your workout progress. |

| Number | Name | Details |
|--------|--|---|
| 4 | Workouts | Examples of workouts: <ul style="list-style-type: none"> • Manual • Heart Rate • Interval • Weight Loss • Variety • Performance |
| 5 | Pause | Use to pause or end a workout session. |
| 6 | OK and Up/Down arrows | Use to navigate options and settings. |
| 7 | Quick Start | Press Quick Start to begin exercising. |
| 8 | <ul style="list-style-type: none"> • Calories • Time Elapsed • Time Remaining • Watts (bike) • Time (bike) | Use the ▲ or ▼ arrows to change what information is displayed. |
| 9 | Incline or Crossramp | Available on treadmill and EFX (dual). |
| 10 | Speed or Resistance | Available on AMT, bike, treadmill, EFX (single), and EFX (dual). |
| 11 | <ul style="list-style-type: none"> • Average Speed (treadmill) • Speed (bike) • Pace (treadmill) • Distance (all equipment) • RPM (bike) • Cals/Min (AMT) • Strides/Min (AMT, EFX) • Total Strides (EFX) | Use the ▲ or ▼ arrows to change what information is displayed. |

Setting Up the Console

Use the System mode to configure settings in ways that benefit your users and your facility. The System menu is visible only to administrators and registered service technicians. Changes made to these settings are saved to the fitness equipment.

The System Settings categories are:

- Club Parameters
- Informational Display

System Settings

System Setting features remain hidden from club patrons and can only be accessed using special keypresses. To view the System Settings, the equipment must be in the Welcome state. The equipment is in the Welcome state when it is on, but not actually in use. This means that there is no exercise session, data entry, or diagnostic operation in progress.

When the equipment is in the Welcome state:

- **SELECT A WORKOUT OR PRESS QUICKSTART TO BEGIN** scrolls in the text display.
- On the treadmill, the belt is not moving and the lift motor is off.

Note: On self-powered equipment, the console initializes when you begin working out. You must maintain a minimum rate of motion for the Welcome banner to appear.

The changes made in System Setting modes become the default settings when the display resets to the Welcome banner.

CAUTION: If you change the Unit of Measure display on the treadmill, check the speed setting to verify that it is correct.

To view the Club Settings:

1. At the Welcome banner, press **Pause**.



2. Press the following number keys in sequence to enter the password:
5 6 5 1 5 6 5
3. Press **OK**.
The Set Club Parameters banner appears.

Table 2. Navigational keys for the system setting modes

| Key | Function |
|--------|---|
| ▲ or ▼ | Navigates the settings menu |
| OK | Selects a menu setting and confirms the changes made to the value setting |
| CLEAR | Returns to the previous menu level without saving changes |
| PAUSE | Exits the System Settings mode and returns to the Welcome banner |

Club Parameters

Use the following information to customize the equipment for your setting.

Note: When you make changes to the club parameters, the new settings replace the factory default settings.

Safety Code (Treadmill only)

Value: Enabled or Disabled

(Default: Disabled)

When the equipment is shipped from the factory, the safety code protection feature is disabled. If you enable the safety code, your users will need to enter a four digit number to begin their exercise session and start the running belt. The code is **1 2 3 4**.

Select Language (All Equipment)

Value: English, Deutsch, Espanol, Francais, Netherlands, Portugues, Rucckijj, and Italiano

(Default: English)

Select your preferred language for the console display.

Note: Programming prompts are not affected by language selection. The prompts in this section continue to appear in English.

Set Units (All Equipment)

Value: U.S. or Metric

(Default: U.S.)

The equipment can display measurements in either Metric or U.S. Standard.

Important: *If you change the Unit of Measure on a treadmill, be sure to check the speed setting to verify that it is correct.*

Set Max Workout Time (All Equipment)

Value Range: 1 to 240 minutes

(Default: 60 minutes)

You can set a maximum workout time per session. Choose a time limit between 1 and 240 minutes, or select **No Limit** if you do not want to set a time limit. For example, if you set the time limit to 20 minutes, users can only enter a workout time between 1 and 20 minutes.

Set Max Pause Time (All Equipment)

Value Range: 1 to 120 seconds

(Default: 120 seconds)

This setting limits how long equipment remains in a paused banner during a workout before it resets.

Note: The optional power adapter must be connected on self-powered equipment to establish a definitive pause time limit. If the optional power adapter is not attached and the rate of motion drops below the minimum requirements, the equipment begins its shutdown, effectively eliminating pause mode.

Set Cool Down Time (All Equipment)

Value Range: 0 to 5 minutes

(Default: 5 minutes)

Select the maximum amount of time the equipment remains in the cool down mode. The cool down time is the period of time following the completion of a program when the user exercises at a reduced work rate.

Set Speed Limit (Treadmill only)

Value Range: Full speed range of equipment

(Default: Maximum speed)

This setting limits how fast the running belt moves and, consequently, the number of speed settings that are available to the user. Use it to set the maximum speed that a user can enter when using the equipment.

The speed is displayed in miles per hour (mph) or kilometers per hour (kph) depending upon the units of measure (U.S. Standard or Metric) selected earlier. The values range from 0.5 to 12 mph (0.8 to 20 kph).

Set Incline Limit (Treadmill only)

Value Range: Full grade range of equipment

(Default: Maximum grade possible)

Select the maximum percent incline that a user can enter when using the equipment. Values range from 0.0 to 15.0.

Hidden Programs (Treadmill only)

Value: Show Programs or Hide Programs

(Default: Hide Programs)

When set to **Show Programs** the Fitness Test is available.

If set to **HIDE PROGRAMS**, when the user presses **PERFORMANCE**, the message **WORKOUT NOT AVAILABLE** will scroll in the text display.

Remote Speed Control (Treadmill only)

Value: Enable or Disable

(Default: Disable)

When this feature is enabled, the CSAFE SetSpeed command and the CSAFE SetGrade command are available if:

- The treadmill is in the CSAFE "InUse" state.
- The speed or grade values sent are within range.

Set Auto Stop (Treadmill only)

Value: On or Off

(Default: On)

Set to **On** to bring the treadmill to a gradual stop when no user is on the equipment. This can occur if a user steps off the equipment during a workout and does not turn it off.

Set Crossramp Auto-level (EFX only)

Value Range: 0 to 20

(Default: 10)

Use this setting to choose a specific ramp incline so that the EFX automatically returns to that incline at the end of a workout session.

Set Resistance Range (Bike only)

Value Range: High, Medium, or Low

(Default: High)

You can set a low, medium, or high base resistance on the recumbent or upright bikes. There are 25 levels of resistance within each base setting, but the base setting affects the overall resistance range. The following ranges are available:

- High: Provides full resistance range.
- Medium: Provides approximately two thirds of the resistance that is available within the high group setting.
- Low: Provides approximately one third of the resistance that is available within the high group setting.

Viewing the Informational Displays

Informational Display settings are values that provide you with information about the equipment. Types of information contained in this setting group include, an event log, software and equipment serial numbers, and usage information.

To view the System settings:

1. At the Welcome banner, press **Pause**.



2. Press the following number keys in sequence to enter the password:

6 5

3. Press **Enter**.

Use the following table to set up customized Informational Display values.

Table 3. Informational Displays values

| Product | Value | Information provided |
|---------|------------|---|
| All | ODOMETER | <p>Correlates to the type of equipment and the standard of units, U.S. or Metric, selected in the programs.</p> <ul style="list-style-type: none"> • Treadmill and AMT: Displays the number of cumulative miles or kilometers logged to date. In addition, the AMT displays the number of vertical strides. • EFX: Displays the number of total strides logged to date. • Bike: Displays the number of total revolutions logged to date. |
| AMT | BELT USAGE | <ul style="list-style-type: none"> • Belt Stride Count: Tracks the number of strides on equipment. • Stride Count Reset: Reset increases by one each time a reset is performed. • Odometer at Last Reset: Records the odometer reading at the time the belt was changed. The equipment odometer continues to count forward after the belt change. |

| Product | Value | Information provided |
|---------|---------------------------|--|
| All | HOUR METER | Displays the number of hours that the equipment has been in use. Note: The equipment tracks the elapsed minutes, but the value that appears is truncated to the nearest full hour. |
| All | UPPER BOOT SW PART NUMBER | Upper board application software part number and version. |
| All | UPPER BASE SW PART NUMBER | Displays the upper base application software version. |
| All | LOWER BASE SW PART NUMBER | Displays the lower application software version. |
| All | METRICS BOARD | Displays the software number on the Metrics Board. |
| All | SERIAL NUMBER | Displays the model and type of equipment. |
| All | USAGE LOG | <ul style="list-style-type: none"> Displays the number of times each workout has been used and displays the associated cumulative minutes. Displays the user preferences in workout selection. |
| All | ERROR LOG | Displays any event codes that may have been detected by the software. For more information, refer to <i>Event Log</i> . |

Event (Error) Log

The event log (sometimes referred to as an error log) contains the following information:

- Event number
- Odometer value when the event occurred
- Hour meter value at the time the event occurred
- Current drawn by the motor when the event occurred (treadmill only)

The following table contains a list of events detectable by the software.

Table 4. Event log numbers and descriptions

| Event Number | Description of Event |
|---------------------|---|
| 00 | Upper PCA memory location event |
| 02 | RAM location event |
| 03 | EEPROM checksum event |
| 05 | Depressed key at power up |
| 09 | Lower PCA memory test event |
| 10 | Line Frequency out of acceptable range |
| 11 | Watchdog (Upper PCA) low voltage power |
| 12 | Watchdog (Lower PCA) low voltage power |
| 13 | Fan at incorrect speed (version 1 treadmills) |
| 14 | Fan fail (Lower PCA) |
| 15 | AC input voltage too high |
| 16 | AC input voltage too low |
| 20 | Too many maximum power requests in one second |
| 21 | Too many maximum consecutive power requests |
| 22 | No motor pulses at start up |
| 23 | Motor pulses missing after start up |
| 24 | Reduce speed requested, speed is not reducing |
| 26 | Motor pulse width incorrect |
| 27 | Too much drive motor current |
| 28 | Temperature too high |
| 29 | Excessive AC input current |
| 30 | Communications event lower board to upper board |

| Event Number | Description of Event |
|---------------------|---|
| 31 | Incorrect Communications event upper board to lower board |
| 32 | Communication event upper board to lower board |
| 33 | Incorrect communications event lower board to upper board |
| 37 | E-STOP error (treadmill only) |
| 40 | Lift motion detected |
| 42 | Lift position value out of range |
| 43 | Zero switch not found |
| 44 | Un-commanded lift motion |
| 45 | Lift going in the wrong direction |
| 50 | Too much brake (magnet) current |
| 53 | Cannot read target, cannot find home switch |
| 54 | Target pulses lost during operation |
| 55 | Brake home switch activated unexpectedly |
| 60 | Auto Stop sensor failure (treadmill only) |
| 61 | Auto Stop not present (treadmill only) |
| 62 | Vertical sensor failure (AMT only) |
| 70 | Belt replacement, lower control board not read (AMT only) |
| 71 | Belt replacement, new lower control board (AMT only) |
| 72 | Belt replacement, lower control board version unknown (AMT only) |
| 73 | Belt replacement, lower control board record bad (AMT only) |
| 74 | Belt replacement, lower control board refurbished console (AMT only) |
| 75 | Belt replacement, refurbished lower control board (AMT only) |
| 76 | Belt replacement, console stride count is less than lower control board (AMT only) |
| 77 | Belt replacement, console stride count is greater than lower control board (AMT only) |
| 78 | Belt replacement warning (AMT only) |
| 79 | Belt replacement required (AMT only) |

User ID Entry with CSAFE Equipment

This equipment is fully compatible with CSAFE protocols. When the equipment is connected to a CSAFE master device, the user is prompted to press ENTER and begin an identification process. The user ID is displayed as five zeros and indicates the starting point. The following table describes key functions while in CSAFE mode.

Table 5. CSAFE access keys

| Keys | Function |
|---------------|---|
| Number Keypad | Use the number keys to enter a user ID. Once you have entered the user ID number, press OK to submit the user ID. |
| CLEAR | Erases individual numbers in the user ID from right to left. |
| OK | Submits the user ID. Note: User ID entry is bypassed when the user enters five zeros. No workout statistics are recorded. |
| PAUSE | Resets to the Welcome banner. |

A message appears on the display and indicates when the user ID is accepted by the CSAFE master device. Once program selection is complete, the user can begin exercising.

Introducing Users to the P10 Console

CAUTION: Before beginning any fitness program, see your physician for a thorough physical examination. Seek advice from your physician to learn the target heart rate appropriate for your fitness level.

The P10 console offers an easy-to-follow display and multiple workouts to help people meet their exercise needs.

Important: Please review the following sections in this guide with your users before allowing them to use the fitness equipment:

- *Important Safety Instructions*
- *Getting Started*
- *Using the Safety Clip (for treadmill only)*

Using the Touch Heart Rate Feature

Note: Touch heart rate performance may vary based on a user's physiology, fitness level, age, and other factors. You may experience an erratic readout if your hands are dry, dirty, or oily, or if the skin on your palms is especially thick. Wearing hand lotion can also cause an erratic readout. In addition, make sure that the sensors are clean to ensure proper contact can be maintained.

To use the touch heart rate feature, place the palm of your hands directly on the metal heart rate sensors on the equipment's handlebars. To ensure an accurate heart rate readout, make sure you follow these tips:

- Both hands must grip the sensors for your heart rate to register.
- It takes a number of consecutive heartbeats (15-20 seconds) for your heart rate to register.

- When gripping the sensors, do not grip tightly. Keep a loose, cupping hold. Holding the grips tightly can affect the reading.
- As you work out, your perspiration will help transmit your heart rate signal. If you have difficulty using the handheld grips to determine your heart rate, try the sensors again later in the workout to see if you can obtain a heart rate signal.
- If the touch heart rate feature does not work for you, Precor recommends that you use a chest transmitter strap.

Heart Rate Target Zones

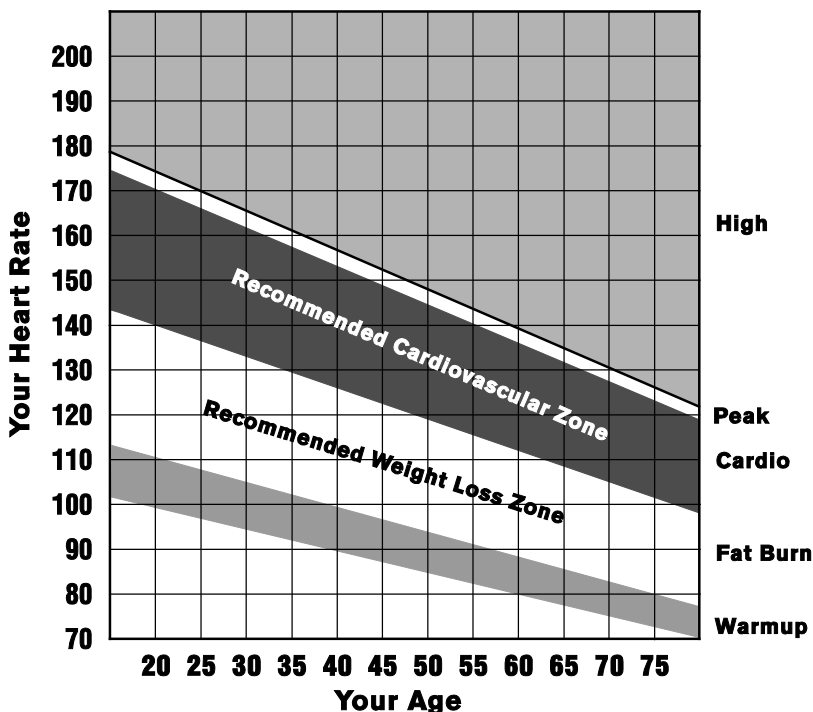

Figure 5: Heart rate target zones

CAUTION: Your heart rate should never exceed 85% of your maximum aerobic heart rate. Your maximum heart rate is equal to 220 minus your age.

Using a Chest Strap Transmitter

WARNING Signals used by the chest strap transmitter (or heart rate strap) may interfere with pacemakers or other implanted devices. Consult your physician and the manufacturers of your chest strap transmitter and implanted device before using a chest strap transmitter.

Wearing a chest strap transmitter during your workout provides steady heart rate information. For the equipment to detect your heart rate, you must grip the touch heart rate sensors or wear a chest strap transmitter while exercising. In the presence of both touch and wireless data, the touch data takes precedence and will display.

Note: To receive an accurate reading, the strap needs to be in direct contact with the skin on the lower sternum (just below the bust line for women).

To use a chest strap transmitter:

1. Carefully dampen the back of the strap with tap water.
***Important:** Do not use deionized water. It does not have the proper minerals and salts to conduct electrical impulses.*
2. Adjust the strap and fasten it around your chest. The strap should feel snug, not restrictive.
3. Make sure that the chest strap is right-side-up, lies horizontally across, and is centered in the middle of your chest.
4. Test the chest strap placement by checking the heart rate function on the equipment. If a heart rate is registering, your chest strap placement is correct. If the equipment does not register a heart rate, readjust the strap and recheck the heart rate function.

Using the Treadmill Safety Clip

The treadmill is equipped with two different stop functions, which behave as follows:

| <i>If the user ...</i> | <i>Then the treadmill belt ...</i> | <i>And the console ...</i> |
|--|------------------------------------|--|
| Pulls on the lanyard attached to the safety clip and trips the restart switch. 1 | Slows to a stop. | Shows the words PUSH TO RESET SWITCH . On some console models, an arrow points toward the Restart switch. |
| Presses down on the red STOP button. 2 | Slows to a stop. | Shows that the exercise workout is paused. |

The restart switch is located just below the console and immediately behind the red **STOP** button, as shown in the following figure. When it is tripped, the bar pops up, displaying the words **PUSH TO RESET** on its front side. The treadmill does not operate while these words are visible.

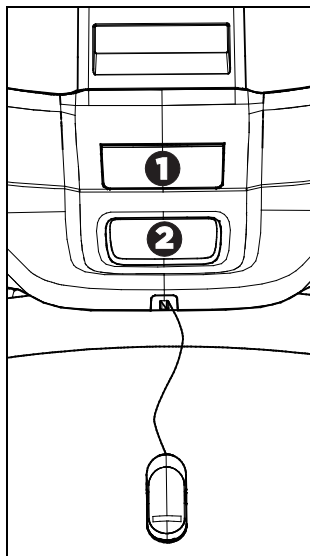

Figure 6: Restart switch

Instruct users on how important it is to use the safety clip while exercising on the treadmill, and demonstrate how they should attach it to their clothing near the waistline.

If the restart switch trips during exercise, perform the following steps:

1. Reattach the safety clip if necessary.
2. Press the restart switch down until it clicks, returning it to its normal position.

Note: If the restart switch trips, all information about the current workout is deleted.

3. Start the workout from the beginning, reducing the time as needed to account for the amount of exercise that has been completed.

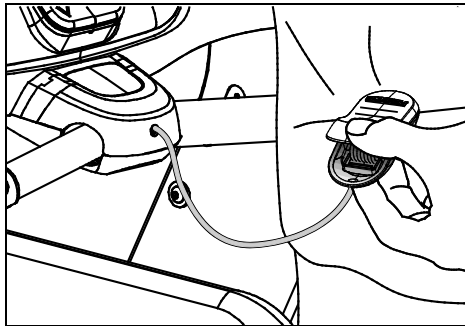

Figure 7: Attaching the safety clip

Treadmill Auto Stop™ (Automatic Stop) Function

Important: *The default setting for this feature is ON. An administrator can turn off this feature in the System Settings; however, Precor recommends it remain ON.*

The Auto Stop™ (Automatic Stop) feature is designed to bring the treadmill to a gradual stop when it is not in use. This might occur if a user steps off the treadmill before the end of a workout and leaves the treadmill running.

Sixty seconds after a treadmill workout starts or resumes, the equipment begins Auto Stop monitoring. If a user is detected, then no message appears, and the selected workout continues.

If no user is detected after an additional 30 seconds, the console displays the message **NO USER DETECTED, STOPPING IN 10 SECONDS** as notification of the pending stop. During the display of this message, a ten second countdown begins. If a user does not override the countdown, the belt comes to a gradual stop after the countdown is complete.

Note: Users weighing more than 90 pounds (41 kg) are detected within the speed and position limits of the feature. Users weighing 50 pounds (22.7 kg) to 89 pounds (40.5 kg) may not be detected depending on their speed and location. Always be aware of and follow the console's instructions for proper operation.

Starting a Workout

CAUTION: If you are using a treadmill, be sure to attach the security clip to your clothing before starting your workout.

The equipment is in the Welcome state when the words **SELECT A WORKOUT OR PRESS QUICKSTART TO BEGIN** scroll across the scrolling text display.

If the equipment is connected to CSAFE, the words **SELECT A WORKOUT, PRESS QUICKSTART, OR ENTER TO BEGIN** scroll across the text display.

If anything else appears on the screen, press **Pause** to display the Welcome banner.

From this screen, there are two ways to begin a workout:

- Press **Quick Start™**.
This action launches the Manual program. Calculations, such as calories used, are based on a 150-lb (68 kg), 35-year old person.
- Press one of the preset workouts.

When a user reaches the club time limit during a workout, the workout limit in minutes appears before the words **CLUB TIME LIMIT REACHED, WORKOUT ENDING**, appear in the text display.

Starting a Preset Programmed Workout

Preset workouts are a great way to tailor your workouts to your fitness goals, stay challenged, and add variety to your sessions. Most P10 equipment contains multiple preset workouts. These workouts include:

- Manual
- Heart Rate
- Interval
- Weight Loss
- Variety
- Performance

Pausing and Resuming an Exercise Session

When you interrupt a workout, the equipment responds in one of two ways, depending on how it is powered.

Paused (Externally Powered Equipment)

When the session is paused, the belt speed is slowly reduced to zero, or the resistance is slowly reduced to the minimum. The lift motor is turned off leaving the incline or crossramp at its current position. Data entry is canceled.

When you press **Pause** on all non-treadmill equipment, it displays the summary screen with your workout metrics. After displaying the summary, it returns to the Welcome screen.

Pending Shutdown (Self-Powered Equipment)

On self-powered machines, the paused state is equivalent to the pending shutdown state. When you stop working out, the equipment begins a 30 second countdown.

The accumulated metrics (e.g., time, strides, distance, calories) hold their current values and do not change. Data entry may not be started.

To restart the program, begin working out again. The resistance is reset to what it was when the program was paused.

If the equipment remains inactive for more than 30 seconds, the power is lost and the equipment bypasses the workout summary screen.

Three different types of metrics are captured during a workout.

Controlled Metrics can be set and changed. They include:

- Resistance Level (AMT, EFX, bike)
- Speed (treadmill)
- Incline (treadmill, EFX)
- Crossramp (EFX)

Current Performance Metrics describe the intensity of a workout in real time. They include:

- Pace (treadmill)
- Heart Rate
- Speed (bike)
- Revolutions/Minute (bike)
- Strides/Minute (AMT, EFX)
- Watts (bike)

Accumulated Metrics describe the overall performance throughout the entire exercise session. They include:

- Time Elapsed
- Time Remaining
- Distance
- Calories
- Time (bike)
- Total Strides (EFX)
- Average Speed (treadmill)

Ending a Session

Cooling down is an important aspect of your workout because it helps reduce muscle stiffness and soreness by transporting excess lactic acid out of the working muscles. In addition, a three to five minute cool down allows your heart rate to return to its normal, resting state.

At the end of your workout, a Summary screen displays your average heart rate during your workout and your accumulated workout metrics.

If you performed a fitness test exercise program, an initial message presents a fitness score.

The next two messages display the user's average and maximum heart rate during the session. These messages are only displayed if heart rate data was acquired during the session, i.e., a valid heart rate number was displayed at least once during the session.

The summary state times out in two minutes, causing a return to the Welcome banner. If the machine is in a CSAFE Finished state then the summary state must last for at least the CSAFE timeout value, typically 10 seconds or less. If it has not lasted that long, then before returning to the Welcome banner, the word **RESETTING** appears until the CSAFE finished state ends.

Maintenance

To keep the equipment functioning properly, perform the minor maintenance tasks in this section at the intervals suggested. Failure to maintain the equipment as described in this section could void the Precor Limited Warranty.

DANGER To reduce the risk of electrical shock, always disconnect the equipment from its power source before cleaning it or performing any maintenance tasks. If the equipment uses an optional power adapter, disconnect the adapter.

Cleaning the Console and Display

The console requires little maintenance once installed. Precor recommends that you clean the console before and after each exercise session.

To remove dust and dirt from the console:

- Wipe all exposed surfaces with a soft cloth that you have moistened with a solution of 30 parts of water to 1 part of Simple Green® (for more information, visit www.simplegreen.com).

Important: Do not use any acidic cleaners. Doing so will weaken the paint or powder coatings and void the Precor Limited Warranty. Never pour water or spray liquids directly on the console or console's screen.

- It is important to avoid using any corrosive chemicals on the console or screen.
- Always dampen the cloth and then clean the screen. Be sure to spray the cleaning liquid onto the cloth, not the console, so that drips do not seep into the console.
- Apply the cleaner with a soft, lint-free cloth. Avoid using gritty cloths.

Changing the Belt (Newer Model AMT Only)

The AMT uses belts to provide motion. These belts eventually wear and must be replaced.

When the belt stride count reaches 90 million, the message **BELTS MUST BE CHANGED SOON** scrolls on the Welcome screen. While this message appears, the AMT operates normally.

Important: *If this message displays on your AMT, please contact Precor Customer Support for assistance.*

When the belt stride count reaches 100 million (and the belt has not been changed), the message **BELTS CHANGE REQUIRED** scrolls continuously on the Welcome screen. The input keys are not functional and the user cannot enter values or begin a workout until the belts are changed. Please contact Precor Customer Support to schedule a belt change.



Precor Incorporated
20031 142nd Avenue NE
P.O. Box 7202
Woodinville, WA USA 98072-4002



P10 OM 302291-101 rev A, en
January 2013

Assembling and Maintaining TRM 800-Series Treadmills



PRECOR[®]

Assembling and Maintaining TRM 800-Series Treadmills

PRECOR®

Edition Information

ASSEMBLING AND MAINTAINING TRM 800-SERIES
TREADMILLS

P/N 300713-401 rev J

Copyright © October 2012 Precor Incorporated. All rights reserved. Specifications subject to change without notice.

Trademark Note

Precor, AMT, EFX, and Preva are registered trademarks of Precor Incorporated. Other names in this document may be the trademarks or registered trademarks of their respective owners.

Intellectual Property Notice

All rights, title, and interests in and to the software of the Preva Business Suite, the accompanying printed materials, any copies of such software, and all data collected via the Preva Business Suite, are exclusively owned by Precor or its suppliers, as the case may be.

Precor is widely recognized for its innovative, award-winning designs of exercise equipment. Precor aggressively seeks U.S. and foreign patents for both the mechanical construction and the visual aspects of its product design. Any party contemplating the use of Precor product designs is hereby forewarned that Precor considers the unauthorized appropriation of its proprietary rights to be a very serious matter. Precor will vigorously pursue all unauthorized appropriation of its proprietary rights.

Precor Incorporated
20031 142nd Ave NE, P.O. Box 7202
Woodinville, WA 98072-4002
1-800-347-4404

<http://www.precor.com>

Important Safety Instructions

Important: *Save these instructions for future reference.*

Read all instructions in the documentation provided with your exercise equipment, including all assembly guides, user guides, and owner's manuals, before installation of this device.

Note: This product is intended for commercial use.

The display apparatus (hereinafter referred to as the *console*) is intended to be shipped with new Precor exercise equipment (hereinafter referred to as the *base unit*). It is not packaged for individual sale.

WARNING To prevent injury, the console must be attached securely to the base unit following all assembly and installation instructions shipped with the base unit. The console is intended to be connected to AC mains power through the furnished power supply ONLY. It should be powered on only when installed as described in the assembly and installation instructions shipped with the base unit. The console is intended for use only with Precor fitness equipment, not as a standalone device.

Safety Precautions

Always follow basic safety precautions when using this equipment to reduce the chance of injury, fire, or damage. Other sections in this manual provide more details of safety features. Be sure to read these sections and observe all safety notices. These precautions include the following:

- Read all instructions in this guide before installing and using the equipment and follow any labels on the equipment.
- Make sure all users see a physician for a complete physical examination before they begin any fitness program, particularly if they have high blood pressure, high cholesterol or heart disease; have a family history of any of the preceding conditions; are over the age of 45; smoke; are obese; have not exercised regularly in the past year; or are taking any medication.

French equivalent of the above notice, for Canadian markets: *Il est conseillé aux utilisateurs de subir un examen médical complet avant d'entreprendre tout programme d'exercice, en particulier s'ils souffrent d'hypertension artérielle, ou de cardiopathie ou ont un taux de cholestérol élevé, s'ils ont des antécédents familiaux des précédentes maladies, s'ils ont plus de 45 ans, s'ils fument, s'ils sont obèses, s'ils n'ont pas fait d'exercices réguliers au cours de l'année précédente ou s'ils prennent des médicaments. Si vous avez des étourdissements ou des faiblesses, arrêtez les exercices immédiatement.*

- Do not allow children, or people unfamiliar with the operation of this equipment, on or near it. Do not leave children unsupervised around the equipment.
- Make sure all users wear proper exercise clothing and shoes for their workouts and avoid loose or dangling clothing. Users should not wear shoes with heels or leather soles, and they should check the soles of their shoes to remove any dirt and embedded stones. They should also tie long hair back.
- Never leave the equipment unattended when it is plugged in. Unplug the equipment from its power source when it is not in use, before cleaning it, and before providing authorized service.

Note: The optional power adapter is considered a power source for self-powered equipment.

- Use the power adapter provided with the equipment. Plug the power adapter into an appropriate, grounded power outlet as marked on the equipment.

- Care should be taken when mounting or dismounting the equipment.
- For Treadmills: Do not use typing or web surfing features while walking at speeds that exceed a **slow and relaxed leisurely pace**. Always stabilize yourself by holding a stationary handle bar while using typing or web surfing features.
- For AMT and EFX: Always stabilize yourself by holding a stationary handle bar while using typing or web surfing features.
- Read, understand, and test the emergency stop procedures before use.
- Keep the power cord or optional power adapter and plug away from heated surfaces.
- Route power cables so that they are not walked on, pinched, or damaged by items placed upon or against them, including the equipment itself.
- Ensure the equipment has adequate ventilation. Do not place anything on top of or over the equipment. Do not use on a cushioned surface that could block the ventilation opening.
- Assemble and operate the equipment on a solid, level surface.

- **SPACING**—The below minimum spacing recommendations are based on a combination of the ASTM (U.S.) voluntary standards and EN (European) regulations as of October 1, 2012, for access, passage around, and emergency dismount:
 - **Treadmills**—a minimum of 0.5 m (19.7 in.) on each side of the treadmill and 2 m (78 in.) behind the machine.
 - **Cardio equipment other than treadmills**—a minimum of 0.5 m (19.7 in.) on at least one side, and .5 m (19.7 in.) behind or in front the machine.

Careful consideration should be given to the requirements of the Americans with Disabilities Act (ADA), US Code 28 CFR (see Section 305). ASTM standards are voluntary and may not reflect current industry standards. The actual area for access, passage around, and emergency dismount is the responsibility of the facility. The facility should consider the total space requirements for training on each unit, voluntary and industry standards, and any local, state, and federal regulations. Standards and regulations are subject to change at any time.

Important: *These spacing recommendations should be used when positioning equipment away from sources of heat, such as radiators, heat registers, and stoves. Avoid temperature extremes.*

- Keep equipment away from water and moisture. Avoid dropping anything on or spilling anything inside the equipment to prevent electric shock or damage to the electronics.
- When using the treadmill, always attach the safety clip to your clothing before beginning your workout. Failure to use the safety clip may pose a greater risk of injury in the event of a fall.
- Keep in mind that heart rate monitors are not medical devices. Various factors, including the user's movement, may affect the accuracy of the heart rate readings. The heart rate monitors are intended only as exercise aids in determining heart rate trends in general.
- Do not operate electrically powered equipment in damp or wet locations.
- Never operate this equipment if it has a damaged cord or plug, if it is not working properly, or if it has been dropped, damaged, or exposed to water. Call for service immediately if any of these conditions exist.

- Maintain the equipment to keep it in good working condition, as described in the *Maintenance* section of the owner's manual. Inspect the equipment for incorrect, worn, or loose components, and then correct, replace or tighten prior to use.
- If you plan to move the equipment, obtain help and use proper lifting techniques.
- Equipment Weight Restrictions: Do not use the treadmill if you weigh more than 500 pounds (225 kg). If you weigh more than 350 pounds (160 kg), do not run on the treadmill. For all other fitness equipment, the weight limit is 350 pounds (160 kg).
- Use the equipment only for its intended purpose as described in this manual. Do not use accessory attachments that are not recommended by Precor. Such attachments may cause injuries.
- Do not operate the equipment where aerosol (spray) products are being used or where oxygen is being administered.
- Do not use outdoors.
- Do not attempt to service the equipment yourself, except to follow the maintenance instructions in the owner's manual.
- Never drop or insert objects into any opening. Keep hands away from moving parts.
- Do not set anything on the stationary handrails, handlebars, control console, or covers. Place liquids, magazines, and books in the appropriate receptacles.
- Do not lean on or pull on the console at any time.



CAUTION: DO NOT remove the cover, or you may risk injury due to electric shock. Read the assembly and maintenance guide before operating. There are no user-serviceable parts inside. Contact Customer Support if the equipment needs servicing. For use with single phase AC power only.

Safety Code

The club owner or manager has the option to enable the safety code. With the code enabled, a user must enter four number keys in the correct order before using the equipment. If the user does not press the correct keys within two minutes, he or she is denied access to the equipment.

Educating Users

Take time to educate users about the Important Safety Instructions found in both the *User Reference Manual* and *Product Owner's Manual*. Explain to your club or facility patrons that they should observe the following precautions:

- Hold onto a stationary handrail or handlebar while assuming the starting position on the equipment.
- Face the console at all times.
- On treadmills, straddle the running belt and attach the safety clip to clothing at waist level before touching the control console.

Important: For safety, make sure users step onto the running belt while it is moving at or below 1 mile per hour (1.6 kilometers per hour).

- Hold on to a stationary handrail or handlebar with one hand whenever you operate the console keys with the other hand.

Hazardous Materials and Proper Disposal

The batteries within self-powered equipment contain materials that are considered hazardous to the environment. Federal law requires proper disposal of these batteries.

If you plan to dispose of your equipment, contact Precor Commercial Products Customer Support for information regarding battery removal. Refer to *Obtaining Service*.

Product Recycling and Disposal

This equipment must be recycled or discarded according to applicable local and national regulations.

Product labels, in accordance with European Directive 2002/96/EC concerning waste electrical and electronic equipment (WEEE), determine the framework for the return and recycling of used equipment as applicable throughout the European Union. The WEEE label indicates that the product is not to be thrown away, but rather reclaimed upon end of life per this Directive.

In accordance with the European WEEE Directive, electrical and electronic equipment (EEE) is to be collected separately and to be reused, recycled, or recovered at end of life. Users of EEE with the WEEE label per Annex IV of the WEEE Directive must not dispose of end of life EEE as unsorted municipal waste, but use the collection framework available to customers for the return, recycling, and recovery of WEEE. Customer participation is important to minimize any potential effects of EEE on the environment and human health due to the potential presence of hazardous substances in EEE. For proper collection and treatment, refer to *Obtaining Service*.

Regulatory Notices for the RFID Module

When equipped with a control console as described in this document, this equipment may include a radio-frequency identification (RFID) module. The RFID module has been certified to operate at temperatures between -20°C and 85°C (-4°F and 185°F).

Radio Frequency Interference (RFI)

The RFID module conforms to the following national standards defining acceptable limits for radio frequency interference (RFI).

Federal Communications Commission, Part 15
This equipment has been tested and found to comply with the limits for a Class A digital device, pursuant to Part 15 of the FCC Rules. These limits are designed to provide reasonable protection against harmful interference in a commercial installation. The equipment generates, uses, and can radiate radio frequency energy and, if not installed and used in accordance with the owner's manual instructions, can cause harmful interference to radio communications.

Operation is subject to the following two conditions: (1) this device may not cause harmful interference, and (2) this device must accept any interference received, including interference that may cause undesired operation.

WARNING Per FCC rules, changes or modifications not expressly approved by the manufacturer could void the user's authority to operate the equipment.

Industry Canada

This device complies with RSS-210:2007 of the Spectrum Management & Telecommunications Radio Standards Specification. Operation is subject to the following two conditions: (1) this device may not cause harmful interference, and (2) this device must accept any interference received, including interference that may cause undesired operation.

This Class A digital apparatus complies with Canadian ICES-003.

Cet appareil numérique de la classe A est conforme à la norme NMB-003 du Canada.

ATTENTION: Haute Tension
Débranchez avant de réparer

European Applications

CE compliance is claimed to the following directives:

- 1999/5/EC R&TTE Directive
- 2006/95/EC LVD Directive
- 2002/95/EC RoHS Directive

Directive compliance has been verified to the following standards:

- EN 55022
- EN 300 330-1 V1.5.1
- EN 300 330-2 V1.3.1
- EN 301 489-3 V1.4.1
- EN 301 489-1 V1.8.1
- EN 60950-1

Regulatory Notices for Cardiovascular Exercise Equipment

The regulatory information in this section applies to the exercise equipment and its control console.

Safety Approvals for Cardiovascular Equipment

Precor equipment has been tested and found to comply with the following applicable safety standards.

Cardiovascular Type Equipment:

- CAN/CSA, IEC, EN 60335-1 (Household and similar electrical appliances - Safety)
- EN 957 (Stationary training equipment, class S/B compliant equipment)

PVS and P80 Regulatory Notice

This Precor equipment has been tested and found to comply with the following applicable safety standards.

- CAN/CSA, UL, IEC, EN 60065 (Audio, video and similar electronic apparatus - Safety)

Radio Frequency Interference (RFI)

This Precor exercise equipment conforms to the following national standards defining acceptable limits for radio frequency interference (RFI).

Federal Communications Commission, Part 15
This equipment has been tested and found to comply with the limits for a Class A digital device, pursuant to Part 15 of the FCC Rules. These limits are designed to provide reasonable protection against harmful interference in a commercial installation. The equipment generates, uses, and can radiate radio frequency energy and, if not installed and used in accordance with the owner's manual instructions, may cause harmful interference to radio communications.

WARNING Per FCC rules, changes or modifications not expressly approved by Precor could void the user's authority to operate the equipment.

Industry Canada

This Class A digital apparatus complies with Canadian ICES-003.

Cet appareil numérique de la classe A est conforme à la norme NMB-003 du Canada.

ATTENTION: Haute Tension
Débranchez avant de réparer

European Applications

CE compliance is claimed to the following directives:

- 2004/108/EC EMC Directive
- 2006/95/EC LVD Directive
- 2002/95/EC RoHS Directive

Directive compliance has been verified to the following standards:

- EN 55022
- EN 55024
- EN 60335-1
- EN 60065 (P80 and PVS)

Treadmill Grounding Instructions

The treadmill must be grounded. If the equipment malfunctions or breaks down, grounding draws off electric current and reduces the risk of electric shock. The power cord on the treadmill is equipped with a grounding conductor and a three-pin grounding plug. This plug must be inserted into an outlet that is properly installed and grounded in accordance with all local codes and ordinances. Failure to ground the treadmill properly may void the Precor Limited Warranty.

DANGER Improper connection of the grounding conductor can result in a risk of electric shock. Check with a qualified electrician or service person if you are not sure whether the equipment is properly grounded. Do not modify the plug provided with the treadmill. If the plug does not fit the outlet, have a proper outlet installed by a qualified electrician.

Electrical Recommendations: 120 V and 240 V Treadmills

Note: This is a recommendation only. NEC (National Electric Code) guidelines or local region electric codes must be followed.

You should have received a power cable that meets your local electrical code requirements along with the equipment. Precor treadmills must be connected to a 20 amp individual branch circuit that can be shared only with one PVS. If you need additional help with the power connections contact your Precor authorized dealer.

Important: An individual branch circuit provides a hot conductor and neutral conductor to a receptacle. The conductors must not be looped, "daisy-chained", or connected to any other conductors. The circuit must be grounded according to NEC guidelines or local region electric codes.

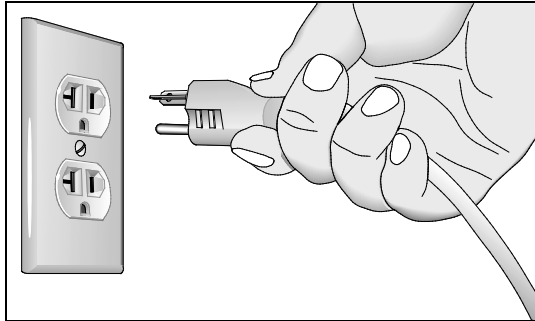

Figure 1: North American 120-volt, 20-amp power receptacle

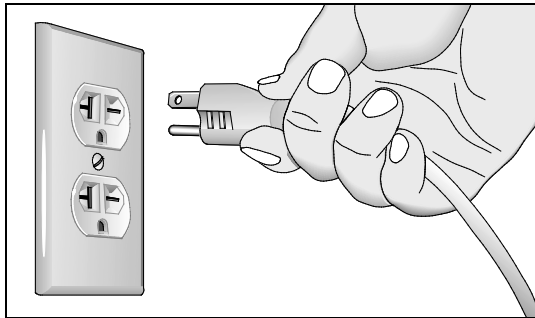

Figure 2: North American 240-volt, 20-amp power receptacle

Obtaining Service

Do not attempt to service the equipment except for maintenance tasks. If any items are missing, contact your dealer. For more information regarding customer support numbers or a list of Precor authorized service centers, visit the Precor web site at <http://www.precor.com>.

Obtaining Updated Documentation

Current Precor product documentation is available at <http://www.precor.com/productmanuals>. You may want to check in for updated information from time to time.

Table of Contents

| | |
|--|-----------|
| Important Safety Instructions | 3 |
| Safety Precautions..... | 4 |
| Safety Code | 7 |
| Educating Users | 8 |
| Hazardous Materials and Proper Disposal..... | 8 |
| Product Recycling and Disposal | 9 |
| Regulatory Notices for the RFID Module | 9 |
| Regulatory Notices for Cardiovascular Exercise Equipment..... | 11 |
| Treadmill Grounding Instructions | 13 |
| Electrical Recommendations: 120 V and 240 V Treadmills | 13 |
| Obtaining Service..... | 14 |
| Obtaining Updated Documentation | 14 |
| | |
| Assembling the Treadmill..... | 17 |
| Installation Requirements..... | 18 |
| Unpacking the Cables..... | 20 |
| Assembling the Frame..... | 22 |
| Completing Assembly | 28 |
| Checking Treadmill Alignment and Adjusting the Running Belt | 29 |
| Leveling the Unit | 30 |
| Plugging In the Power Cord..... | 31 |
| Breaking in the Equipment | 32 |
| | |
| Installing the Console | 33 |
| Threading the Cable Assembly (P80) | 34 |
| Connecting Cables (P80)..... | 36 |
| Completing the Console Installation (P80)..... | 42 |
| Threading the Cable Assembly (P30 and P10) | 42 |
| Connecting Cables (P30 and P10)..... | 44 |
| Completing the Console Installation (P30 and P10)..... | 46 |
| Reassembling the Treadmill Fairing | 47 |
| Verifying That the Heart Rate Display Is Operational | 48 |

Maintenance.....49
Daily Cleaning 49
Daily Inspection 50
Weekly Maintenance 51
Monthly Maintenance 51
Checking the Alignment of the Running Belt.....52
Adjusting the Running Belt53
Storing the Chest Strap..... 54
Moving the Equipment55
Long-Term Storage..... 56

Treadmill Safety Features 57
Entering the Safety Code.....57
Using the Treadmill Safety Clip 58
Turning the Treadmill On and Off 59
Weight Limit..... 59
Location..... 60

Commercial Cardiovascular Equipment Limited Warranty..... 61

Assembling the Treadmill

Important: The instructions in the following procedures are described from the perspective of a person standing **directly in front of the equipment** (that is, on the opposite side of the control console from a person using the equipment). These descriptions may not match the names of certain parts in the parts list, because such parts are named relative to the back of the equipment.

WARNING You will need assistance to assemble this unit. **DO NOT attempt assembly by yourself.**

To prepare the treadmill for assembly:

1. Have your assistant help place the shipping carton close to the location where you plan to use the treadmill. Break down the sidewalls of the shipping carton so that they lie flat. Remove the loose contents of the carton.

CAUTION: Use safe lifting techniques throughout the following steps. To prevent injury to yourself or damage to the equipment, obtain appropriate assistance before removing the unit from the pallet.

2. With the help of as many assistants as necessary, lift the treadmill off of the pallet and roll it gently onto the floor.
3. **Make sure that the power switch is OFF.** Check the ON/OFF power switch on the front of the treadmill. Place the switch in the O (OFF) position. Make sure that the treadmill is **not** plugged into a power source.

Note: In the following step, do not roll the treadmill over its power cord.

4. Lift the unit by placing hands on opposite sides of the rear cross brace found under the treadmill's running belt. Roll the treadmill on its front wheels to the area where it will be used.

5. Remove the shipping fasteners from the front panel using a ¼-inch hex key and a ½-inch box-end wrench.
6. Remove any tape or wire ties securing the console cable to the side of the unit.

Before you begin, verify that you have received the following parts:

- Base frame assembly
- Left and right upright supports
- Center fairing with handrails
- Hardware kit

Installation Requirements

The location where the treadmill is installed must provide power connections that supply the appropriate voltage, a 20A individual branch circuit, and grounding per NEC (National Electric Code) guidelines or local region electric code.

CAUTION: Do not use a non-grounded outlet or transformer. Do not remove or otherwise bypass the plug with an adapter. Electrical damage can occur and void the Precor Limited Warranty if the treadmill is connected to an improper power source.

Required Tools

- ¼-inch hex wrench
- 5/32-inch hex wrench (ball end is desirable)
- ½-inch box-end wrench
- Bubble level
- #2 Phillips screwdriver
- String or fish tape
- Wire cutter

Hardware Kit (not to scale)

The hardware kit shipped with this equipment contains the fasteners and other hardware components shown in the following table. Before you begin assembly, make sure that your hardware kit is complete. If not, please contact Precor Customer Support.

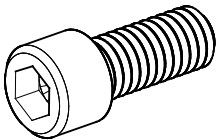
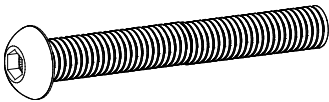
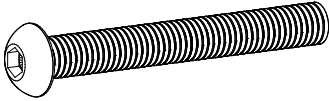
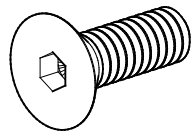
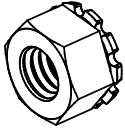
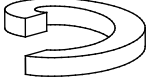
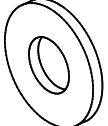
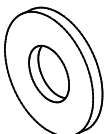
| Fasteners | Quantity |
|---|---|
|  | 5/16-inch x 3/4-inch socket head screws 8 |
|  | 5/16-inch x 3/4-inch buttonhead screws (zinc finish) 6 |
|  | 5/16-inch x 3/4-inch buttonhead screws (black finish) 4 |
|  | Flat head hex drive screws (1/4-inch x 5/8-inch) 4 |
|  | 5/16-inch locknuts with star washers 4 |
|  | 5/16-inch split lock washers 10 |
|  | 5/16-inch flat washers (zinc finish) 6 |
|  | 5/16-inch flat washers (black finish) 12 |

Note: Retrieve the cables and other hardware shipped with the console before you begin installation.

Unpacking the Cables

To connect the console to the base unit, you may need up to five cables, as follows:

- Ethernet (P80 only)
- Television (P80 only)
- Power (P80 only)
- Base unit data
- Automatic stop sensor (Auto Stop™)

The first three of these cables are shipped with the P80 console. The remaining two are shipped inside the treadmill fairing.

To unpack the cables:

1. Open the box containing the P80 console. Retrieve the Ethernet, television, and power cables.
2. Remove the two screws holding the center column cover in place. Remove the cover and set it aside, along with the two screws.

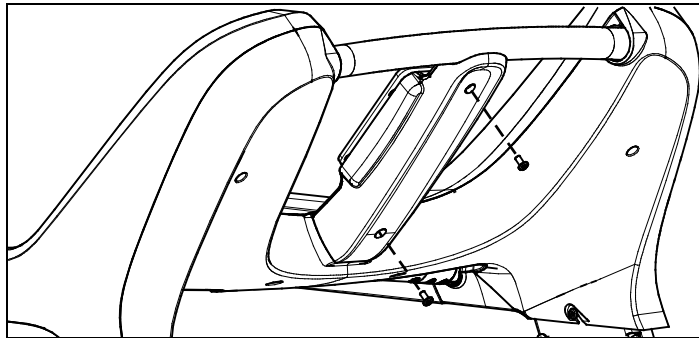

Figure 3: Removal and replacement of the center column cover

3. Remove the seven screws holding the back cover in place. Snap the back cover loose and set it aside, along with the seven screws.

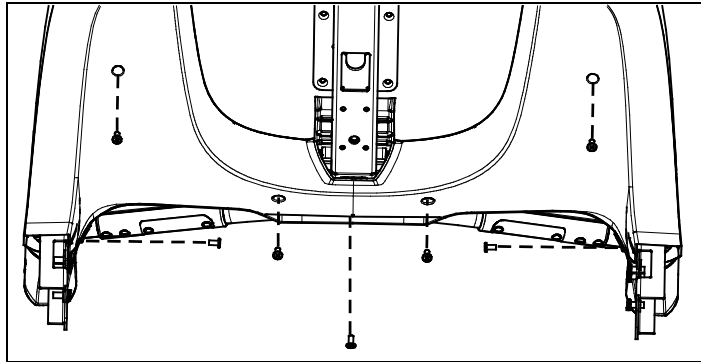

Figure 4: Removal and replacement of the rear fairing cover

4. Remove the two ends of the base unit data cable from the left arm of the fairing (position 1 in the following illustration). Route the shorter of the two cable ends into the fairing and extend the long end outward.

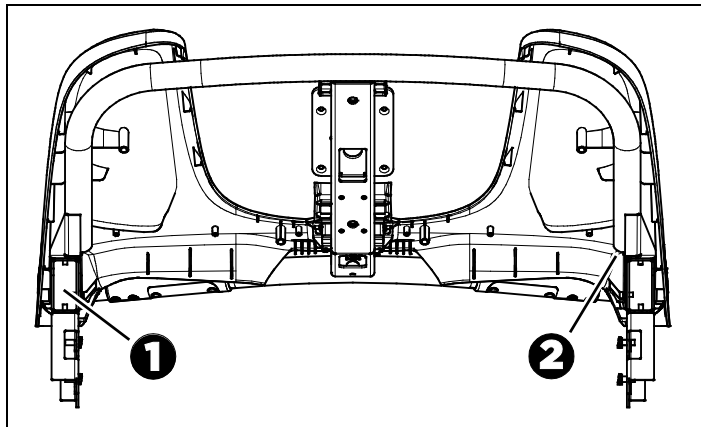

Figure 5: Cable storage locations in the treadmill fairing: base unit data cable (1) and Auto Stop cable (2)

5. Remove the Auto Stop cable from the tube on the right-hand side of the fairing (position 2 in the preceding illustration).

Important: In the following step, make sure that the end of the data cable with the ferrite bead is the upper end. Likewise, on the automatic stop sensor cable, the three-conductor socket is the lower end and the four-conductor socket is the upper end.

6. Remove any tape that secure the cables, then unwind them and remove any kinks. Gather the cables into a single bundle (referred to later as the *cable assembly*). Do not remove the cable tie that secures the ferrite to the cable to the frame.

Note: Arranging the cables so that the connectors are slightly staggered at the bottom end (but still within one inch or three centimeters overall) can help when feeding the cable assembly through narrow openings in the frame.

Assembling the Frame

DANGER Make sure that the treadmill is not connected to any power source before you begin the following procedures.

As you add the left-hand and right-hand upright supports to the treadmill base, you will need to make sure that the cable assembly is threaded properly through the left-hand support so that the necessary connections are available when you add the control console. A fish tape (a thin metal strip with a hook or clasp on one end, available from professional hardware vendors) can be helpful during this procedure.

To begin assembly of the frame:

1. Remove the hood and set it aside.

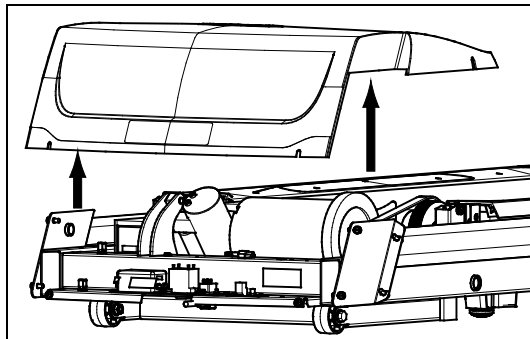

Figure 6: Hood removal

2. Place the right-hand upright support into the base frame side bracket.
3. Secure the right-hand upright support to the side bracket using four socket head screws, four black washers, and two locknuts. Partially tighten the fasteners.

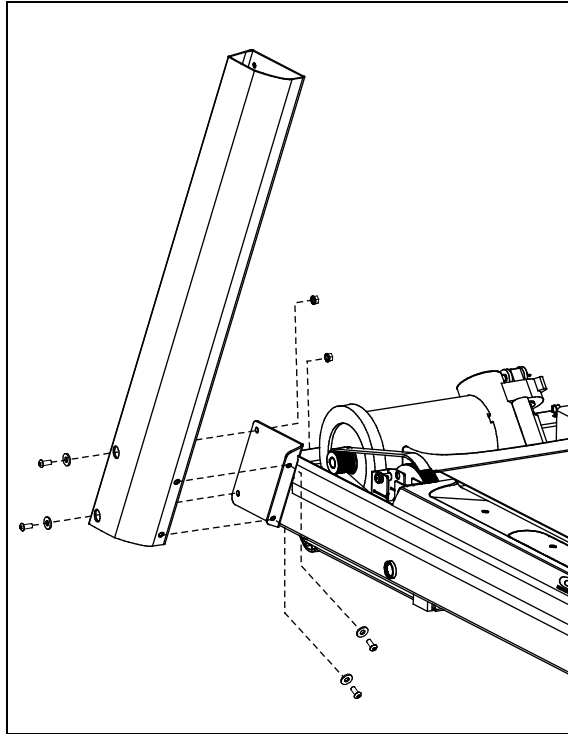
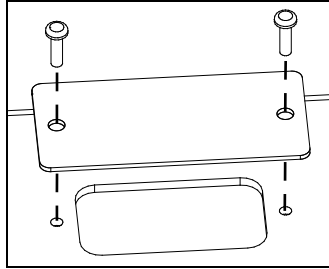

Figure 7: Upright support attachment, right side

4. Using the Velcro connectors provided, attach the power supply to the right-hand side of the front crossmember on the treadmill base.
5. Route the DC output cable of the power supply through the clips between the power supply and the belt motor. Pass the end of the cable under the mounting bracket for the lift motor.
6. Connect the black three-conductor plug on the AC wiring harness to the socket on the power supply.

To install the accessory jack panel (treadmills with P80 consoles only):

1. Remove the two #10 x 1/2-inch Philips-head machine screws securing the blank plate at the right front corner of the treadmill, as shown in the following figure.

**Figure 8: Blank plate removal**

2. Place the jack panel over the opening and replace the two machine screws. Tighten the screws completely.

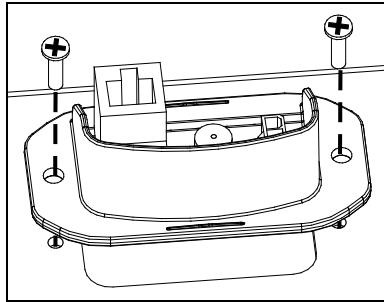
**Figure 9: Coupler installation**

To thread cables through the frame:

1. Feed the cable assembly downward through the left-hand upright support and out through the opening in the lower end of the support. Drape the remaining cable over the front of the support and tape it into place if necessary to secure it temporarily.
2. Feed the cable assembly through the grommet in the left-hand side bracket of the base frame. Connect the individual cables as shown in the following illustration and table.

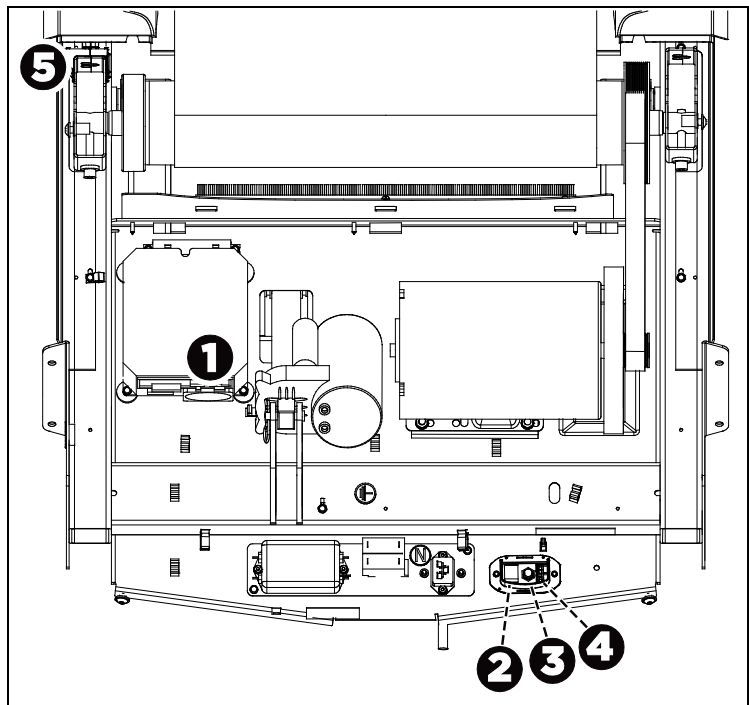

Figure 10: Cable connections and mounting points in the treadmill base

Table 1. Cable connections and mounting points in the treadmill base

| Component | Appearance | Already Installed | Lower connection point |
|-----------------------------|--|-------------------------------------|-------------------------------|
| Base unit data cable | Flat with silver insulation | Yes | 1 |
| Ethernet cable | Round with black insulation | No | 2 |
| Television cable | Round with black insulation | No | 3 |
| Console power cable | Dual leads with red and black insulation | Yes | 4 |
| Automatic stop sensor cable | Round with silver insulation | Yes (included in treadmill fairing) | 5 |

CAUTION: Be careful not to cut or pinch any wires during the following step.

3. Place the left-hand upright support into the base frame side bracket.

4. Secure the left-hand upright support to the side bracket using four socket head screws, four black washers, and two locknuts. Partially tighten the fasteners.

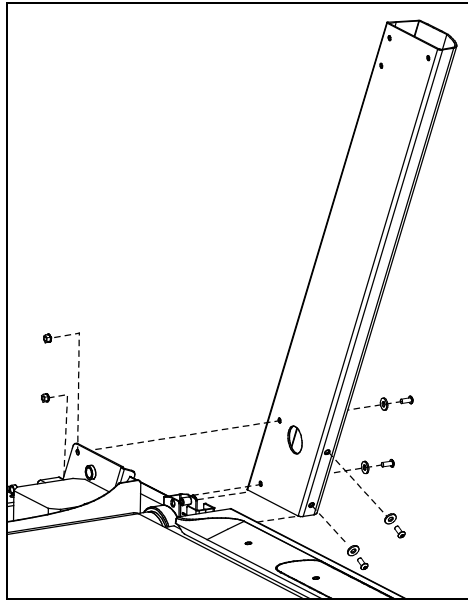

Figure 11: Upright support attachment, left side

5. Lower the treadmill fairing assembly over the upright supports and align it to them.
Important: In the following step, take care not to unseat any of the components in the stop switch.
6. Feed the upper end of the cable assembly through the fairing so that its upper end extends through the bottom opening in the center column and out the round opening in the console mounting plate.
7. Route the cable assembly through the cable guides in the fairing, then wrap the guides around the cable assembly to secure it. Push any extra cable into the upright support.

Note: In the following step, use the zinc-finish buttonhead screws and flat washers from the hardware kit.

Important: Do not wrench-tighten the fasteners in the following step until the unit has been fully assembled. Make sure the fasteners do not pinch any cables. The Precor Limited Warranty does not cover cables damaged by improper installation.

8. Secure the fairing assembly using six buttonhead screws and six washers. Partially tighten the fasteners.

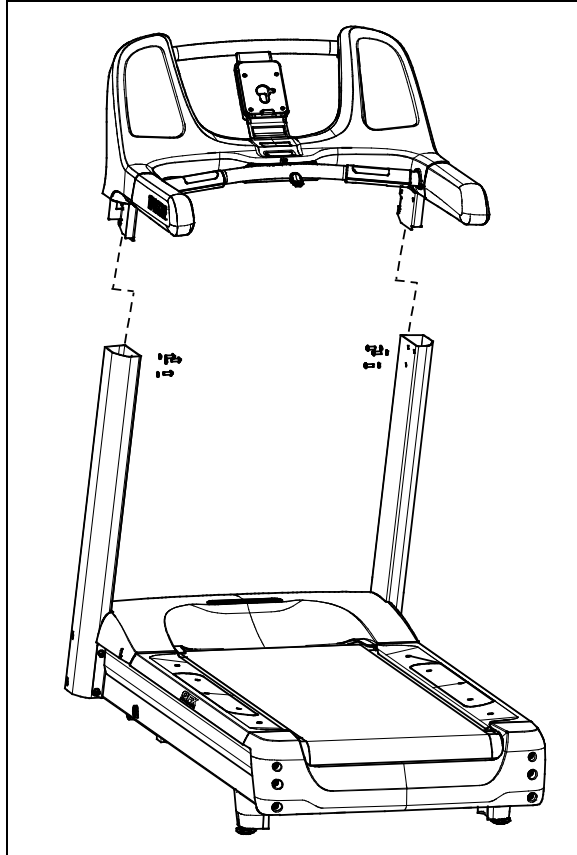

Figure 12: Handrail and console assembly attachment

Completing Assembly

After the upright supports and the fairing are in place, replace the hood on the treadmill base and finish securing the fasteners.

CAUTION: Be aware of the handrail extensions when you are working around the front of the unit. It is easy to bump your head or sustain other injuries if you ignore the location of the handrail extensions.

To secure the fasteners:

1. Using an alternating order, tighten the eight fasteners that secure the upright supports to the treadmill base.
2. Fully tighten the six screws that secure the console fairing to the upright supports.

To complete assembly of the treadmill base:

Important: Use your fingers to align and thread the four hood fasteners properly. Then use a wrench to tighten the hood fasteners completely as described in the following step.

1. Thread the four black buttonhead screws (with black washers) into their holes, leaving gaps of about $\frac{1}{4}$ inch between the washers and the surface of the treadmill frame.
2. Place the front of the hood on the two front screws. Make sure the screws are aligned with the notches in the hood and the washers are outside the hood.
3. Lower the back of the hood until the side screws rest inside the notches in the internal wall of the hood. Make sure the washers are outside the internal wall (on the same side as the screw heads).
4. Tighten all four screws securely, starting with the front screws.

Note: Using a hex wrench, reach through the openings in the outer sides of the hood to tighten the side screws.

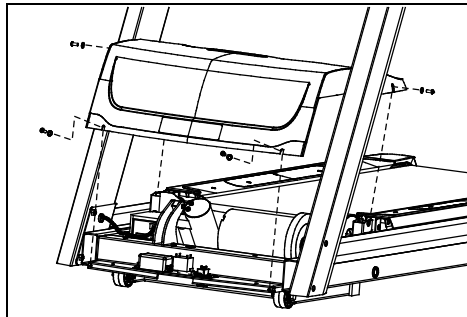

Figure 13: Hood and fastener placement

Checking Treadmill Alignment and Adjusting the Running Belt

Before you allow anyone to use the treadmill, you must check the alignment of the running belt and adjust it as needed. For more information, refer to *Checking the Alignment of the Running Belt* and *Adjusting the Running Belt* in the *Maintenance* chapter.

Leveling the Unit

The treadmill deck must be absolutely level from side to side to keep the belt in alignment and ensure proper operation. If the load is not equally distributed across the treadmill deck, users may feel excessive vibration or observe it at the console. You must make sure the deck is level before allowing anyone to use the treadmill.

Important: Observe the following precautions throughout this procedure:

- Adjust only one rear foot at a time.
- Do not raise the unit beyond $\frac{3}{4}$ inch (2 cm).
- Install the unit only on an absolutely even surface. Adjusting the rear feet cannot compensate for variations in the surface under the unit.

To level the treadmill:

1. Place a bubble level across the running belt to see whether the treadmill is level.

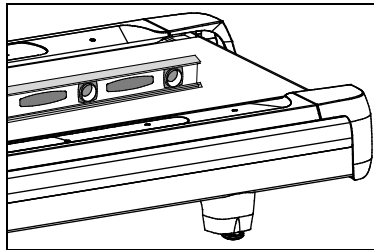

Figure 14: Bubble level placement on running belt

If the treadmill ... Then ...

Is level Skip to the next procedure.

Is **not** level Continue with step 2.

2. Position yourself next to the adjustable rear feet.

Important: Be sure that your assistant uses proper lifting techniques in the following step.
3. Ask a capable assistant to lift the rear portion of the treadmill (using proper lifting techniques).

4. Adjust the rear feet as needed.

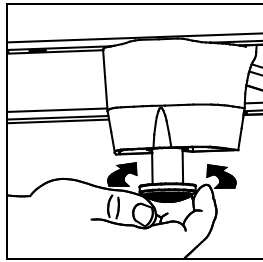

Figure 15: Leveling foot adjustment

5. Repeat steps 1 through 4 until the treadmill is level.
6. If necessary, adjust the rear feet so that the user's weight is distributed evenly on the treadmill.

Plugging In the Power Cord

CAUTION: Use the supplied power cord. Do not remove or otherwise bypass the 3-prong plug with an adapter to use a non-grounded outlet. Do not plug the unit into a power transformer in an attempt to adjust the voltage requirements. Failure to follow these instructions might damage the unit and void the Precor Limited Warranty.

After assembly is complete, plug the power cord into an appropriate outlet.

Important: *The treadmill requires a 20-amp individual branch circuit grounded per NEC (National Electric Code) guidelines or local region electric code.*

Breaking in the Equipment

Precor equipment does not require an actual break-in period. However, moving components such as belts, gears, and bearings can settle while the equipment is being stored or shipped. This can cause the equipment to operate with a small amount of roughness or noise when it starts up for the first time.

The equipment usually returns to smooth operation after a day or two of normal use. If it does not, contact your dealer for assistance. For more information, refer to *Obtaining Service*.

Installing the Console

To make installation easier, all Precor Experience Series consoles use the same mounting hardware and connector locations whenever possible. The installation sequence for any of them is as follows:

- Threading the cable assembly
- Connecting cables
- Completing the installation (tightening the mounting screws and attaching the back cover)

The following sections describe how to perform these tasks.

Threading the Cable Assembly (P80)

Earlier in the installation, you threaded the necessary cables through the frame of the base unit and out the passthrough opening in the console mount. As you line up the back plate on the console with the console mount, you must make sure that the cable assembly passes correctly through the openings in both components.

Important: Before you begin the following procedure, remove the rear cover from the control console. To remove the cover, use your fingernails to pry the lower edge loose, then swing the cover up and out as shown in the following illustration.

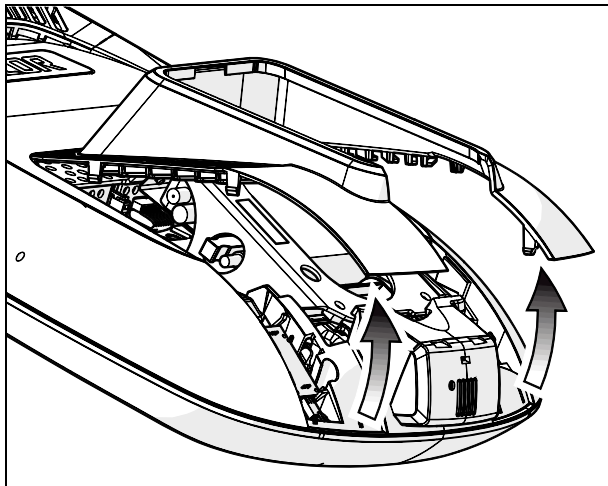

Figure 16: Removing the access cover from the P80 console

To thread the cable assembly:

1. Make sure that as much of each cable as possible passes through the opening in the middle of the console mount on the base unit.
2. Position the console over the console mount.

3. Rest the console on the console mount so that the notch on the bottom of the console's back plate rests on the rectangular hook at the bottom of the console mount, as shown in the following figure.

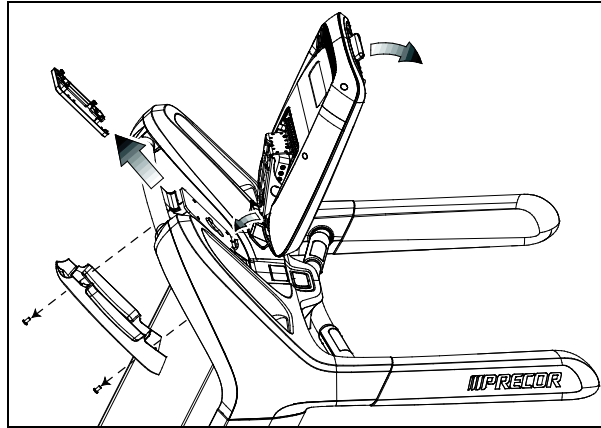

Figure 17: Console positioning on base unit

4. Tilt the console forward until it stops. Use one hand to steady the console in this position, or ask your assistant to do so.
5. Using a #2 Phillips screwdriver, remove the two #8-32 x 1/2" pan-head machine screws securing the upper back cover of the fairing, as shown in the previous figure. Set the cover and the screws aside.

Connecting Cables (P80)

After the console has been seated, separate the individual cables out of the end of the cable assembly and attach them to the appropriate circuit connectors inside the console. Refer to the following diagram and table to identify the cables and connectors.

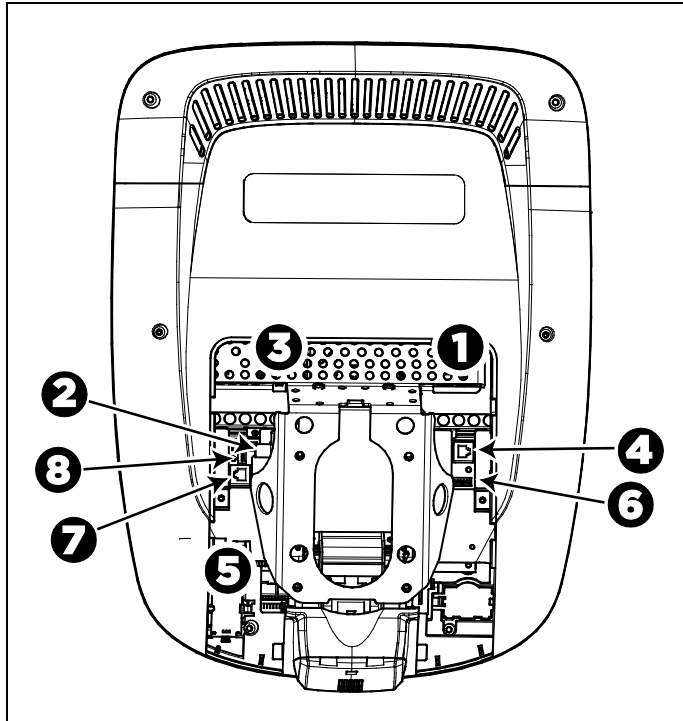

Figure 18: Cable connections, P80 console

Table 2. P80 internal cable connections

| Cable | Connector Type | Circuit Connector Location |
|---|---|----------------------------|
| Ethernet (LAN) | Eight-contact modular, on round black cable | 1 |
| TV in | F-type coaxial | 2 |
| Power | Two-contact plug, polarized and latched | 3 |
| Data from base unit | Eight-contact modular, on flat gray cable | 4 |
| Heart rate sensors | Four-contact strip, keyed | 5 |
| Safety key (treadmills only) | Six-contact strip, keyed | 6 |
| CSAFE | Eight-contact modular, on flat gray cable | 7 |
| Automatic stop sensor (treadmills only) | Vertical four-contact strip, keyed | 8 |

To simplify installation and maintenance, route and connect cables 1 through 5 according to the following instructions.

Note: In the illustrations in this section, some cables are omitted for the sake of clarity.

Connecting the Television Cable

The console's television tuner is mounted inside the console's back plate. The tuner includes a short cable adapter that allows the television cable to be connected outside the back plate.

To connect the television cable:

1. Pull the cable out through the lower right corner of the back plate.
2. Route the cable counterclockwise around the outside of the back plate.

Important: In the following step, install the cable using a torque wrench and torque not to exceed 8 lb-in. If a torque wrench is not available, install the coaxial cable using a plain wrench and tighten to "snug + ¼ turn." You may also use a wrench on the internal nut to help tighten the connection.

3. Attach the connector on the cable to the connector on the tuner cable and tighten the two connectors securely using two $\frac{7}{16}$ -inch open-end wrenches. Position both connectors above the upper right corner of the back plate.
4. Use a plastic tie to secure the connectors to the top of the back plate. Pass the tie through the two small holes near the upper right corner of the back plate, then wrap it around the connectors and tighten it securely. Cut off and remove the protruding end of the tie.

The following illustration shows how the cable is positioned once it is installed.

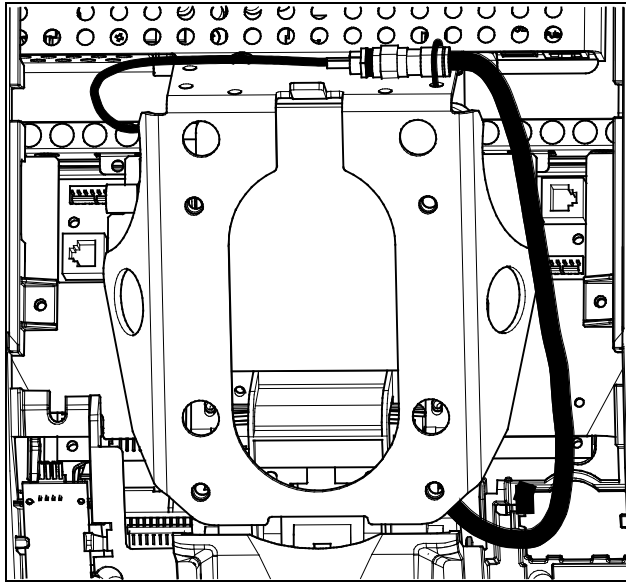

Figure 19: Connecting the television cable

Connecting the Ethernet and Base Unit Data Cables

Both the Ethernet and base unit data cables pass through the cutaway opening at the upper right corner of the back plate and connect to nearby modular jacks in the console. Because of this, it is important to exercise caution when connecting the cables. The black Ethernet cable connects to a jack just underneath the perforated metal bracket at the very top of the opening in the console. The gray base unit data cable connects to a lower jack closer to the back plate.

Refer to the following illustration for the correct position of both cables.

CAUTION: If you connect the base unit data cable to the wrong jack, the equipment will not function.

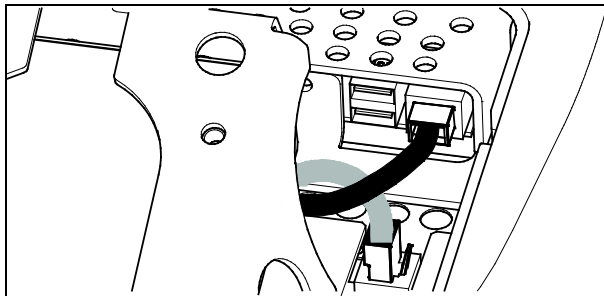

Figure 20: Connecting the Ethernet and base unit data cables

Connecting the Heart Rate Sensor Cable

The heart rate sensor cable passes through the cutaway opening at the upper left corner of the back plate, then down to the small circuit board at the lower left of the console. The following illustration shows how the cable should look once it is installed.

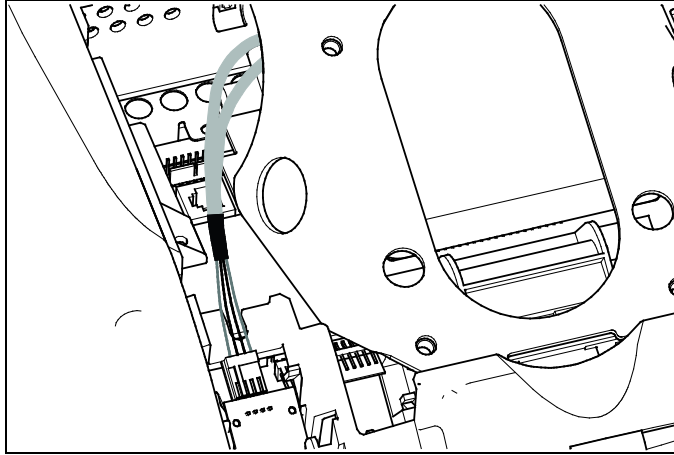

Figure 21: Connecting the heart rate cable

Connecting the Power Cable

Route the power cable through the cutaway opening at the upper left corner of the back plate. In the nearby opening within the steel console framework, locate the socket that matches the power cable plug and connect the power cable to it.

Note: Be sure that the latch on the plug clicks into place on the socket.

The following illustration shows how the cable should look once it is installed.

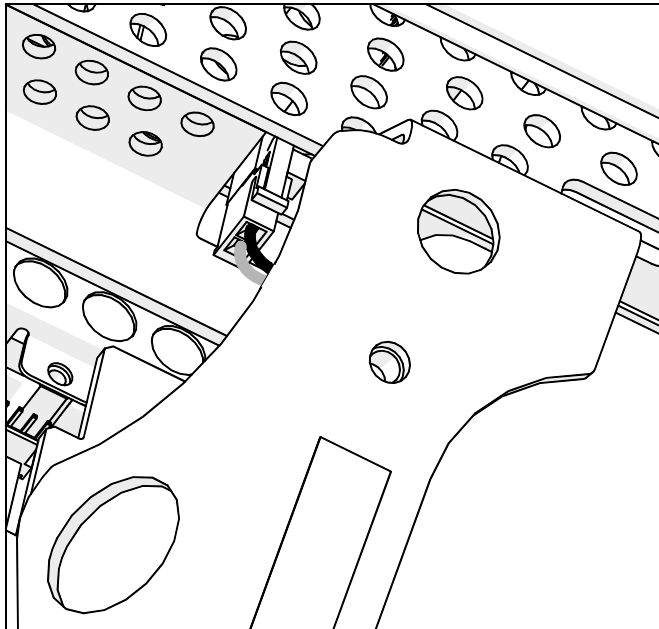

Figure 22: Connecting the power cable

Completing the Console Installation (P80)

Before you complete the final installation steps, double-check the connections you have made. Make sure that all cables are fully and securely connected, and that any unneeded cables are tied back properly.

To complete the installation:

1. Feed extra cable back into the neck tube.
2. Tilt the control console backward (toward yourself) until the tab on the top edge of its back plate slides along the top edge of the console mount and the screw holes align properly.
3. Insert the four $\frac{5}{8}$ -inch flat head screws through the holes in the console mount and thread them into the holes in the back plate on the console. Partially tighten the screws using a $\frac{5}{32}$ -inch hex wrench.
4. Line up the two small tabs at the top of the console's back cover with the slots at the top of the opening in the console case. Insert the tabs into the slots.
5. Insert the remaining tabs on the back cover with the corresponding slots on the console case.
6. Press gently on the edges of the back cover to snap it into place.

Threading the Cable Assembly (P30 and P10)

Earlier in the installation, you threaded the necessary cables through the frame of the base unit and out the passthrough opening in the console mount. As you line up the back plate on the console with the console mount, you must make sure that the cable assembly passes correctly through the openings in both components.

Important: Before you begin the following procedure, remove the rear cover from the control console. Set the cover and its mounting hardware aside for later use.

To thread the cable assembly:

1. Make sure that as much of each cable as possible passes through the opening in the middle of the console mount on the base unit.
2. Position the console over the console mount.

3. Rest the console on the console mount so that the notch on the bottom of the console's back plate rests on the rectangular hook at the bottom of the console mount, as shown in the following figure.

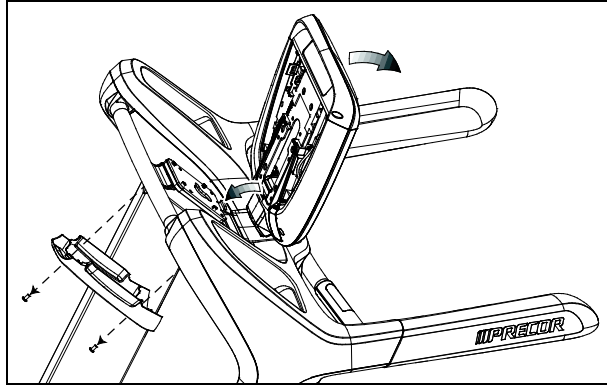

Figure 23: Console positioning on base unit

4. Tilt the console forward until it stops. Use one hand to steady the console in this position, or ask your assistant to do so.
5. Pull all cables upward and forward until you can drape them over the top of the console's back plate.

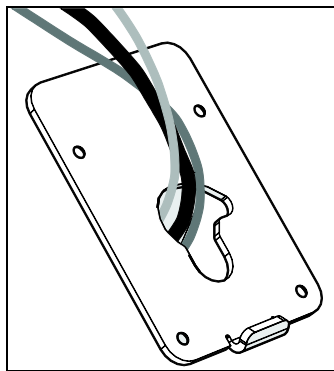

Figure 24: Cable positioning

Connecting Cables (P30 and P10)

Important: Pass all cables through the semicircular opening just above the console mount, as shown in the following figure. **Do not** attempt to route any cables through other openings or through the steel channel above the mount.

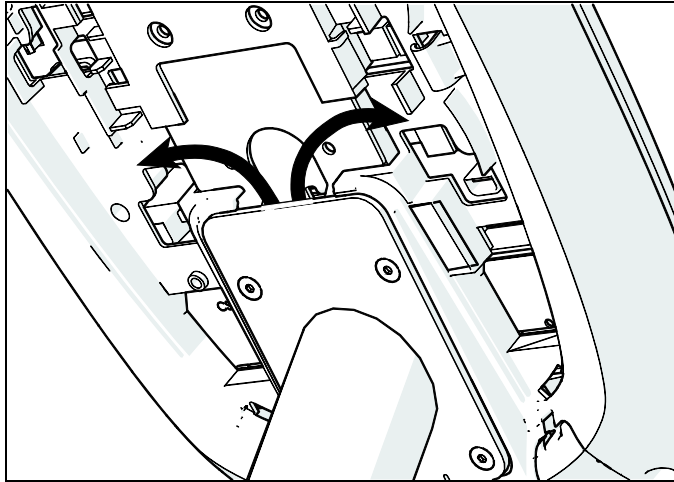

Figure 25: Cable routing from the mount into the console

After the console has been seated, separate the individual cables out of the end of the cable assembly and attach them to the appropriate circuit connectors inside the console. Refer to the following diagram and table to identify the cables and connectors.

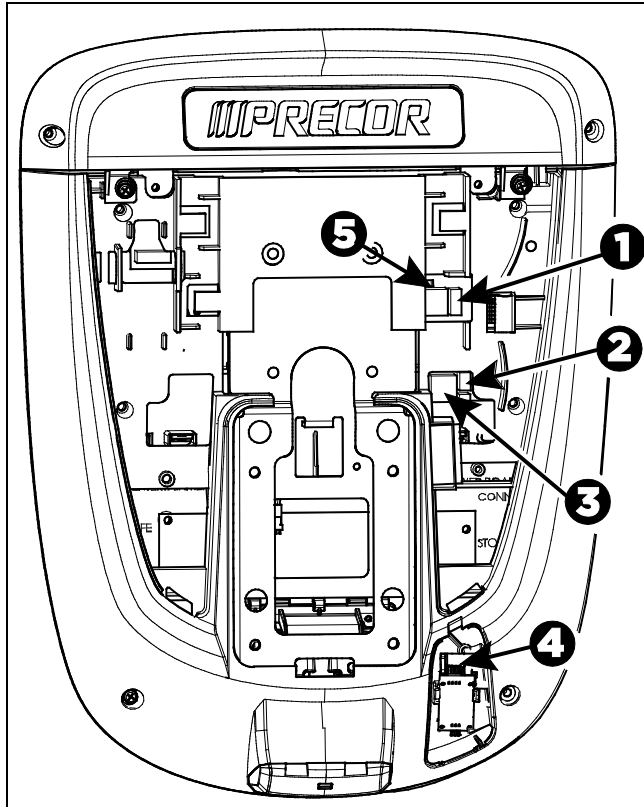

Figure 26: Cable connections, P30 and P10 consoles

Table 3. P30 and P10 internal cable connections

| Cable | Connector Type | Circuit Connector Location |
|---|---|----------------------------|
| Safety key (treadmills only) | Six-contact strip, keyed | 1 |
| Automatic stop sensor (treadmills only) | Four-contact strip, keyed | 2 |
| Data from base unit | Eight-contact modular, on flat gray cable | 3 |
| Heart rate sensors | Four-contact strip, keyed | 4 |
| CSAFE | Eight-contact modular, on flat gray cable | 5 |

Completing the Console Installation (P30 and P10)

Before you complete the final installation steps, double-check the connections you have made. Make sure that all cables are fully and securely connected, and that any unneeded cables are tied back properly.

To complete the installation:

1. Feed extra cable back into the neck tube.
2. Tilt the control console backward (toward yourself) until the tab on the top edge of its back plate slides along the top edge of the console mount and the screw holes align properly.
3. Insert the four $\frac{5}{8}$ -inch flat head screws through the holes in the console mount and thread them into the holes in the back plate on the console. Partially tighten the screws using a $\frac{5}{32}$ -inch hex wrench.

4. Line up the two small tabs at the bottom of the console's back cover with the slots at the bottom of the console case. Insert the tabs into the slots.
5. Insert the two #8-32 x 1/2-inch Phillips-head screws that you removed earlier into the holes at the top edge of the console's back cover. Tighten the screws fully.
Important: Use caution not to pinch the cables between the back cover and PVS mounting screw heads.
6. Fully tighten the four mounting screws (partially tightened in step 3) using a 5/32-inch hex wrench.

Reassembling the Treadmill Fairing

After the console is in place, reattach the two cover panels of the treadmill fairing.

Important: In the following procedure, do not allow the fasteners to break or pinch any cables.

To reassemble the fairing:

1. Verify that the cable assembly is secure inside the cable clips and that the ferrite bead on the base unit data cable is tied securely into place in the left arm of the treadmill.
2. Snap the rear cover into place and attach the seven screws you removed with it earlier.

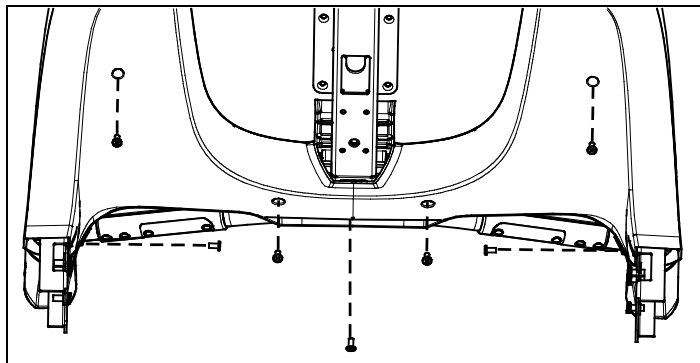

Figure 27: Removal and replacement of the rear fairing cover

3. Hold the center column cover in place and attach the two screws you removed with it.

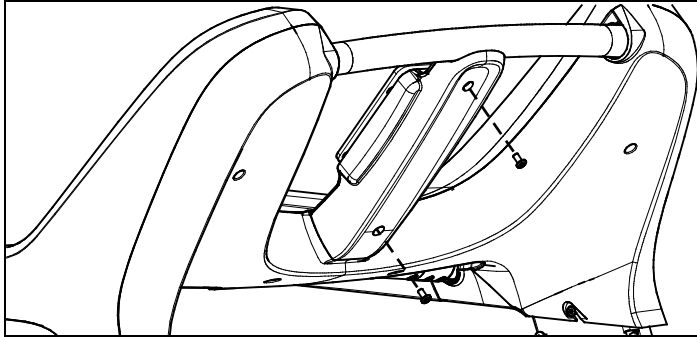

Figure 28: Removal and replacement of the center column cover

Verifying That the Heart Rate Display Is Operational

To verify that the heart rate display is operational:

1. Begin exercising on the equipment.
2. Grasp both touch-sensitive handlebars.
Note: The heart rate is read within ten seconds. During that time, the heart on the display flashes. You must maintain contact with both metal plates on each handlebar to ensure an accurate reading.
3. Look at the HEART RATE display. After a few seconds, a number appears indicating your heart rate.
4. If a number does not appear in the HEART RATE display, perform the following checks:
 - Verify that the cable connection is properly connected.
 - Repeat the test with a different person. Although the heart rate display is generally highly accurate, it may not work properly for a few individuals.

Note: If you use wireless heart rate monitoring, repeat this test using a chest strap or a wireless pulse simulator instead of grasping the touch-sensitive handlebars.

Maintenance

To keep the equipment functioning properly, perform the minor maintenance tasks in this section at the intervals shown on the maintenance checklist. Failure to maintain the equipment as described in this section could void the Precor Limited Warranty.

DANGER To reduce the risk of electrical shock, always disconnect the equipment from its power source before cleaning it or performing any maintenance tasks. If the equipment is self-powered but also uses the optional power adapter, disconnect the adapter.

Daily Cleaning

Precor recommends that you clean the equipment before and after each exercise session. To remove dust and dirt from the equipment, wipe all exposed surfaces with a soft cloth that you have moistened with one of the following cleaners:

- A solution of 30 parts of water to 1 part of Simple Green® (for more information, visit www.simplegreen.com)
- ENVIR-O-SAFE oxygen enhanced cleaner or multi-task cleaner concentrate, diluted according to the manufacturer's instructions (for more information, visit www.daleyinternational.com)

Alternatively, you can clean the equipment with Athletix fitness equipment cleaning wipes (for more information, visit www.athletixproducts.com)

CAUTION: Read and follow the manufacturer's instructions, particularly dilution instructions, before using any cleaner on Precor fitness equipment. Do not use concentrated cleaners at full strength, or acidic cleaners of any kind; such cleaners weaken the protective finish on the equipment and void the Precor Limited Warranty. Never pour water or spray liquids onto any part of the equipment. Allow the equipment to dry completely before using.

Vacuum the floor underneath the equipment frequently to prevent the accumulation of dust and dirt that can interfere with its operation. Use a soft nylon scrub brush to clean the running belt.

CAUTION: On treadmills, as you clean the hood or side rails, remain aware of the handrail extensions to avoid injury.

Daily Inspection

At least once every day, examine the equipment for the following problems:

- Slipping belts
- Loose fasteners
- Unusual noises
- Worn or frayed power cords
- Worn, damaged, or missing safety lanyards or clips
- Any other indication that the equipment may be in need of service

Important: *If you determine that the equipment needs service, disconnect all power connections (television, Ethernet, and power) and move the equipment away from the exercise area. Place an OUT OF SERVICE sign on the equipment and make it clear to all patrons and other users that they must not use it.*

To order parts or to contact a Precor authorized service provider in your area, refer to *Obtaining Service*.

Weekly Maintenance

Perform the following maintenance tasks every week:

1. Elevate the tread to maximum incline, then turn off the power switch or circuit breaker and unplug the unit from the wall outlet.
2. Clean the floor under the equipment using a vacuum cleaner or a damp mop.
3. When the floor is completely dry, reconnect the power and return the treadmill to the level position.
4. Inspect the power cord to verify that it is not pinched under the equipment or between any two moving parts.
5. Test all console functions, including heart rate monitoring features.
6. Verify that the unit sits squarely on the floor. All of its feet should be touching the floor and the unit should not rock or wobble when in use. If not, re-level it as described in *Leveling the Unit*.

Monthly Maintenance

Perform the following maintenance tasks every month:

1. Turn off the power switch or circuit breaker, then unplug the unit from the wall outlet.
2. Inspect the running bed and belt for wear.
3. Clean the treadmill's frame using a cloth moistened with water or an approved cleaner.
4. Use water and a soft nylon scrub brush to clean the outer surface of the running belt.
5. Wipe the exterior of the console with a damp sponge or soft cloth, and dry with a clean towel. Keep water away from electronic components to prevent electrical shock or damage.
6. Clean the touchscreen using a soft, lint-free cloth dampened with a 91% isopropyl alcohol solution (either as sold or diluted with an equal amount of water).
7. Remove the front cover and remove any lint or debris, being careful not to damage the fan.
8. Vacuum out any debris, being careful not to bring the vacuum cleaner nozzle too close to any circuit board (unless your vacuum cleaner is protected against static buildup).

9. Clean and lubricate the lift motor screw with an approved grease such as SuperLube® with Teflon® or Mobil 1® synthetic grease.
10. Check all fasteners for proper tightness and torque.
11. Replace all covers.
12. Verify that the unit sits squarely on the floor. All of its feet should be touching the floor and the unit should not rock or wobble when in use. If not, re-level it as described in *Leveling the Unit*.

Checking the Alignment of the Running Belt

Proper alignment allows the belt to remain centered and ensures smooth operation. Realigning the belt takes a few simple adjustments. If you are unsure about this procedure, call Precor Customer Support (refer to *Obtaining Service*).

Caution: Do not adjust the running belt when someone is standing on it.

To check the alignment of the running belt:

1. Make sure that the running surface is as level as possible. If necessary, adjust the rear feet to level the treadmill (refer to *Leveling the Unit*).
Note: Adjusting the rear feet cannot compensate for extremely uneven surfaces. If you cannot make the running surface level and stable, move the treadmill.
2. Turn the treadmill ON.
3. Standing **beside** the treadmill (not on it), press GO on the console.
4. If necessary, enter the safety code by pressing the number keys in sequence. The running belt starts automatically after a 3-second countdown appears on the console.
5. Press the SPEED UP key until the console shows a speed of 3 mph (5 kph).

CAUTION: If you hear any chafing or the running belt appears to be getting damaged, stop the running belt immediately by pressing the red STOP button. Contact Precor Customer Support.

6. Observe the belt from the rear of the treadmill for a few minutes. The belt should remain centered along the running bed. If it drifts off center, adjust it. Refer to *Adjusting the Running Belt*.

Important: Failure to align the belt may cause the belt to tear or fray, which is not covered by the Precor Limited Warranty.

7. Press the red STOP button to stop the belt.
8. Turn the treadmill OFF.

Adjusting the Running Belt

If you are unsure about adjusting the running belt, call Precor Customer Support (refer to *Obtaining Service*).

CAUTION: Take special care when aligning the running belt. Turn OFF the treadmill while adjusting or working near the rear roller. Do NOT wear loose clothing or allow your hair to hang loose during this procedure. Do NOT adjust the running belt when someone is standing on it. Be very careful to keep your fingers and any other object clear of the belt and rollers, especially in front of the roller and behind the deck. The treadmill will not stop immediately if an object becomes caught in the belt or rollers.

Important: Make all belt adjustments on the adjusting bolts at the rear corners of the treadmill, using the hex key provided, and do not turn either bolt more than $\frac{1}{4}$ turn before checking the alignment of the running belt again. Overtightening the adjusting bolts can damage the treadmill.

To adjust the running belt:

1. Locate the adjusting bolts in the end caps at the rear corners of the treadmill, as shown in the following diagram.

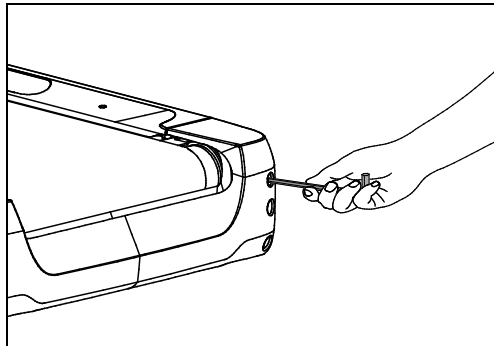

Figure 29: Location of the adjustment bolt

2. Use the hex key to tighten the adjusting bolt toward which the belt is shifting. Turn the bolt $\frac{1}{4}$ turn clockwise.
3. Recheck the belt position as described under *Checking the Alignment of the Running Belt*.

If the belt ...

Then ...

Continues to shift in the original direction

Turn the **same** adjusting bolt an additional $\frac{1}{4}$ turn clockwise.

Starts to shift in the opposite direction

Turn the **same** adjusting bolt $\frac{1}{8}$ turn or less counterclockwise.

Note: If the belt slips after you have adjusted it, tighten **both** adjusting bolts evenly, $\frac{1}{4}$ turn at a time, until the slipping stops. Do not overtighten the belt.

Storing the Chest Strap

If you purchased the optional heart rate chest strap, store it in a place where it remains free of dust and dirt (for example, in a closet or drawer). Be sure to protect the chest strap from extremes in temperature. Do not store it in a place that may be exposed to temperatures below 32° F (0° C).

To clean the chest strap, use a sponge or soft cloth dampened in mild soap and water. Dry the surface thoroughly with a clean towel.

Moving the Equipment

The equipment is very heavy. If you plan to move it to a new location, obtain the help of an adult assistant and use proper lifting techniques. If the equipment includes roller wheels on one end, use the wheels to reduce the load on yourself and your assistant.

Important: *The plastic end caps on Precor treadmills are designed specifically for lifting. Working with your assistant, place a hand under each side of the end cap. Then, using proper lifting techniques, lift the rear of the treadmill so that it rolls on its front wheels.*

The treadmill can be easier to move if it is in an inclined position.

To put the treadmill into an inclined position for moving:

1. Press GO on the console.
2. Increase the incline level to 4 or more.
3. While the treadmill is running, turn the main power switch OFF.
4. Disconnect the treadmill's power cord.

Long-Term Storage

If you do not expect anyone to use the equipment for a long time, perform the following tasks to prepare it for storage:

- Turn it OFF.
- If it has a power cord, disconnect the cord.
- If it has an optional power adapter, connect the adapter to prevent damage to the internal battery.
- Position it so that it will not become damaged and will not interfere with people or other equipment.

Treadmill Safety Features

Before allowing users on Precor equipment, review the in this manual. You should also teach your patrons how to use the equipment safely, according to the guidelines on.

Entering the Safety Code

When the equipment is shipped from the factory, safety code protection is not active.

After you have activated the safety code, you must inform your patrons that the equipment requests a safety code to prevent unauthorized use. They must complete the following steps to use the equipment.

To enter the safety code and start the treadmill:

1. Assume the starting position, with one hand free to enter the code and the other hand holding a handrail.

Important: *Hold the handrail securely with at least one hand throughout the following steps.*

2. When you see the banner text on the console, select a program or press GO.
3. When you are prompted to enter the safety code and unlock the treadmill, press the 1, 2, 3, and 4 keys in order.

If you have entered the code correctly, the workout begins. Otherwise, the equipment pauses for two seconds and then prompts you to enter the code again. Pressing five or more keys returns you to the initial safety code prompt.

Note: On a treadmill, a 3-second countdown appears on the console before the running belt starts to move.

Using the Treadmill Safety Clip

The treadmill is equipped with two different stop functions, which behave as follows:

| <i>If the user ...</i> | <i>Then the treadmill belt ...</i> | <i>And the console ...</i> |
|---|------------------------------------|--|
| Presses down on the red STOP button 2 | Slows to a stop | Shows that the exercise workout is paused |
| Pulls on the lanyard attached to the safety clip and trips the restart switch 1 | Slows to a stop | Shows the words PUSH TO RESET SWITCH and an arrow pointing to the Restart switch |

The restart switch is located just below the console and immediately behind the red **STOP** button, as shown in the following figure. When it is tripped, the bar pops up, displaying the words **PUSH TO RESET SWITCH** on its front side. The treadmill does not operate while these words are visible.

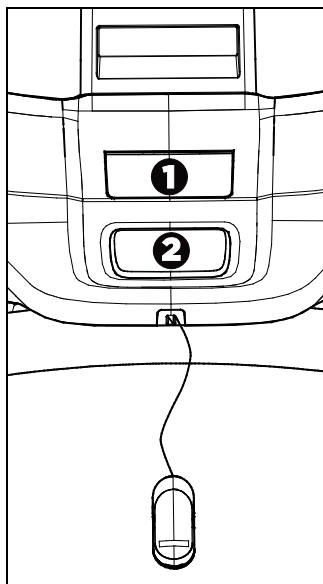

Figure 30: Restart switch

Instruct users on how important it is to use the safety clip while exercising on the treadmill, and demonstrate how they should attach it to their clothing near the waistline.

If the restart switch trips during exercise, perform the following steps:

1. Reattach the safety clip if necessary.
2. Press the restart switch down until it clicks, returning it to its normal position.

Note: If the restart switch trips, all information about the current workout is deleted.

3. Start the workout from the beginning, reducing the time as needed to account for the amount of exercise that has been completed.

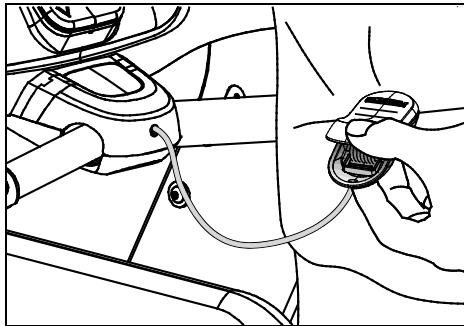

Figure 31: Attaching the safety clip

Turning the Treadmill On and Off

To turn the treadmill ON and OFF, use the power switch located beneath the hood, near the power cord receptacle.

Important: When the treadmill is not being used, turn it OFF.

Weight Limit

Do not use the treadmill if you weigh more than 500 pounds (225 kg). If you weigh more than 350 pounds (160 kg), do not run on the treadmill.

Location

The area around the treadmill must remain open, and free of interference from objects such as other equipment, at all times. In addition, for user safety and proper maintenance, an area three feet (one meter) wide by six feet (two meters) long must remain open and free of interference directly behind the running belt.

Commercial Cardiovascular Equipment Limited Warranty

PLEASE READ THESE WARRANTY TERMS AND CONDITIONS CAREFULLY BEFORE USING YOUR PRECOR INCORPORATED PRODUCT. BY USING THE EQUIPMENT, YOU ARE CONSENTING TO BE BOUND BY THE FOLLOWING WARRANTY TERMS AND CONDITIONS.

Limited Warranty.

Precor Incorporated warrants all new Precor products to be free from defects in materials and manufacture for the warranty periods set forth below. The warranty periods commence on the invoice date of the original purchase. This warranty applies only against defects discovered within the warranty period and extends only to the original purchaser of the product. Parts repaired or replaced under the terms of this warranty will be warranted for the remainder of the original warranty period only. To claim under this warranty, the buyer must notify Precor or your authorized Precor dealer within 30 days after the date of discovery of any nonconformity and make the affected product available for inspection by Precor or its service representative. Precor's obligations under this warranty are limited as set forth below.

Warranty Periods and Coverage.

All Commercial Cardiovascular Products (excluding StretchTrainer, Strength Products, and coverage specific to certain models and options as defined below):

- Frame: 7 years
- Treadmill drive motor: 5 years
- Items subject to wear: 1 year
- All other parts (including mechanical parts and electronic parts): 2 years
- Labor: 1 year

880 Line Commercial Cardiovascular Products (superseding the coverage above where applicable):

- Labor on the P80 console: 2 years
- High wear items on the P80 console, including headphone jack, USB connector, and iPod® connector: 90 days

Options / Accessories

Many options or accessories have components that are connected internally or mounted inside the electronic console. The following guidelines determine the warranty for these components. If the internal components are installed by the factory or by an authorized dealer as part of the original sale and delivery, they have a warranty that is identical to the warranty of the equipment in which they are connected or mounted. If the internal components are not installed by the factory or by an authorized dealer as part of the original sale and delivery, they have a 90 days parts and labor limited warranty. All components that are not internally connected have a 90 days parts only limited warranty. Satisfactory proof of purchase is required in all cases.

Conditions and Restrictions.

This warranty is valid only in accordance with the conditions set forth below:

1. The warranty applies to the Precor product only while
 - a. it remains in the possession of the original purchaser and proof of purchase is demonstrated.
 - b. it has not been subjected to accident, misuse, abuse, improper service, or non-Precor modification.
 - c. claims are made within the warranty period.
2. This warranty does not cover damage or equipment failure caused by electrical wiring not in compliance with electrical codes or Precor owner's manual specifications, or failure to provide reasonable and necessary maintenance as outlined in the owner's manual.
3. Precor is not responsible for Internet connectivity to its products. This restriction applies to services, such as those provided by an Internet service provider (ISP), and also to hardware related to Internet connectivity, such as Ethernet cabling, routers, servers and switches.
4. Precor is not responsible for the quality of television, video, audio, or other media supplied to its products. This restriction applies to services, such as those provided by a cable or satellite television provider; to signal strength and clarity; and also to hardware related to the reception and delivery of television, video, audio, and other media. Such hardware can include (but is not limited to) audio, video, and radio-frequency (RF) cabling, connectors, receivers, modulators, combiners, distribution amplifiers, splitters, and so on.
5. Precor cannot guarantee that the heart rate measurement system on its products will work for all users. Heart rate measurement accuracy varies based on a number of factors, including the user's physiology and age, the method in which the heart rate measurement system is used, external interference, and other factors that may influence heart rate acquisition.
6. Except in Canada, Precor does not pay labor outside the United States.
7. Warranties outside the United States and Canada may vary. Please contact your local Dealer for details.

This Limited Warranty shall not apply to:

1. Software version upgrades.
2. Software defects that do not materially and negatively affect the normal performance of the product under normal conditions of use.
3. Consumable goods or cosmetic items of the product, the exterior of which has been damaged or defaced as a result of abuse, misuse, accident, improper service or installation, mishandling, or modification in design or construction not authorized by Precor.
4. Repairs performed on Precor equipment missing a serial number or with a serial tag that has been altered or defaced.
5. Service calls to correct installation of the equipment or instruct owners on how to use the equipment.
6. Pickup and delivery involved with repairs.
7. Any labor costs incurred beyond the applicable labor warranty period.

Disclaimer and Release.

The warranties provided herein are the exclusive warranties given by Precor and supersede any prior, contrary or additional representations, whether oral or written. ANY IMPLIED WARRANTIES, INCLUDING THE WARRANTY OF MERCHANTABILITY OR FITNESS FOR A PARTICULAR PURPOSE THAT APPLY TO ANY PARTS DESCRIBED ABOVE ARE LIMITED IN DURATION TO THE PERIODS OF EXPRESS WARRANTIES GIVEN ABOVE FOR THOSE SAME PARTS. PRECOR HEREBY DISCLAIMS AND EXCLUDES THOSE WARRANTIES THEREAFTER. Some States do not allow limitations on how long an implied warranty lasts, so the above limitation may not apply to you. PRECOR ALSO HEREBY DISCLAIMS AND EXCLUDES ALL OTHER OBLIGATIONS OR LIABILITIES, EXPRESS OR IMPLIED, ARISING BY LAW OR OTHERWISE, WITH RESPECT TO ANY NONCONFORMANCE OR DEFECT IN ANY PRODUCT, INCLUDING BUT NOT LIMITED TO: (A) ANY OBLIGATION, LIABILITY, RIGHT, CLAIM OR REMEDY IN TORT, WHETHER OR NOT ARISING FROM THE NEGLIGENCE OF PRECOR OR ITS SUPPLIERS (WHETHER ACTIVE, PASSIVE OR IMPUTED); AND (B) ANY OBLIGATION, LIABILITY, RIGHT, CLAIM OR REMEDY FOR LOSS OF OR DAMAGE TO ANY EQUIPMENT. This disclaimer and release shall apply even if the express warranty set forth above fails of its essential purpose.

Exclusive Remedies.

For any product described above that fails to conform to its warranty, Precor will provide, at their option, one of the following: (1) repair; (2) replacement; or (3) refund of the purchase price. Precor Limited Warranty service may be obtained by contacting the authorized dealer from whom you purchased the item. Precor compensates Servicers for warranty trips within their normal service area to repair commercial equipment at the customer's location. You may be charged a trip charge outside the service area. THESE SHALL BE THE SOLE AND EXCLUSIVE REMEDIES OF THE BUYER FOR ANY BREACH OF WARRANTY.

EXCLUSION OF CONSEQUENTIAL AND INCIDENTAL DAMAGES.

PRECOR AND/OR ITS SUPPLIERS SHALL HAVE NO OBLIGATION OR LIABILITY, WHETHER ARISING IN CONTRACT (INCLUDING WARRANTY), TORT (INCLUDING ACTIVE, PASSIVE, OR IMPUTED NEGLIGENCE AND STRICT LIABILITY), OR OTHERWISE, FOR DAMAGE TO THE EQUIPMENT, PROPERTY DAMAGE, LOSS OF USE, REVENUE OR PROFIT, COST OF CAPITAL, COST OF SUBSTITUTE EQUIPMENT, ADDITIONAL COSTS INCURRED BY BUYER (BY WAY OF CORRECTION OR OTHERWISE) OR ANY OTHER INCIDENTAL, SPECIAL, INDIRECT, OR CONSEQUENTIAL DAMAGES, WHETHER RESULTING FROM NONDELIVERY OR FROM THE USE, MISUSE OR INABILITY TO USE THE PRODUCT. This exclusion applies even if the above warranty fails of its essential purposes and regardless of whether such damages are sought for breach of warranty, breach of contract, negligence, or strict liability in tort or under any other legal theory. Some states do not allow the exclusion or limitation of incidental or consequential damages, so the above limitation may not apply to you.

This warranty gives you specific legal rights, and you may also have other rights, which vary from state to state.

Complete this portion and keep for your records.

Purchased From: _____
Example: Dealer or store name.

Phone Number: _____
Example: Dealer or store telephone number.

Product/model: _____
Example: AMT 885 or EFX 883.

Serial number: _____
The serial number is found on the shipping container.

Effective 1 November 2010
P/N 36286-114



Precor Incorporated
20031 142nd Avenue NE
P.O. Box 7202
Woodinville, WA USA 98072-4002

TRM 800-Series PAG/OM 300713-401 rev J
Warranty #36286-114
October 2012